

ratio:
1/2 - 1/3

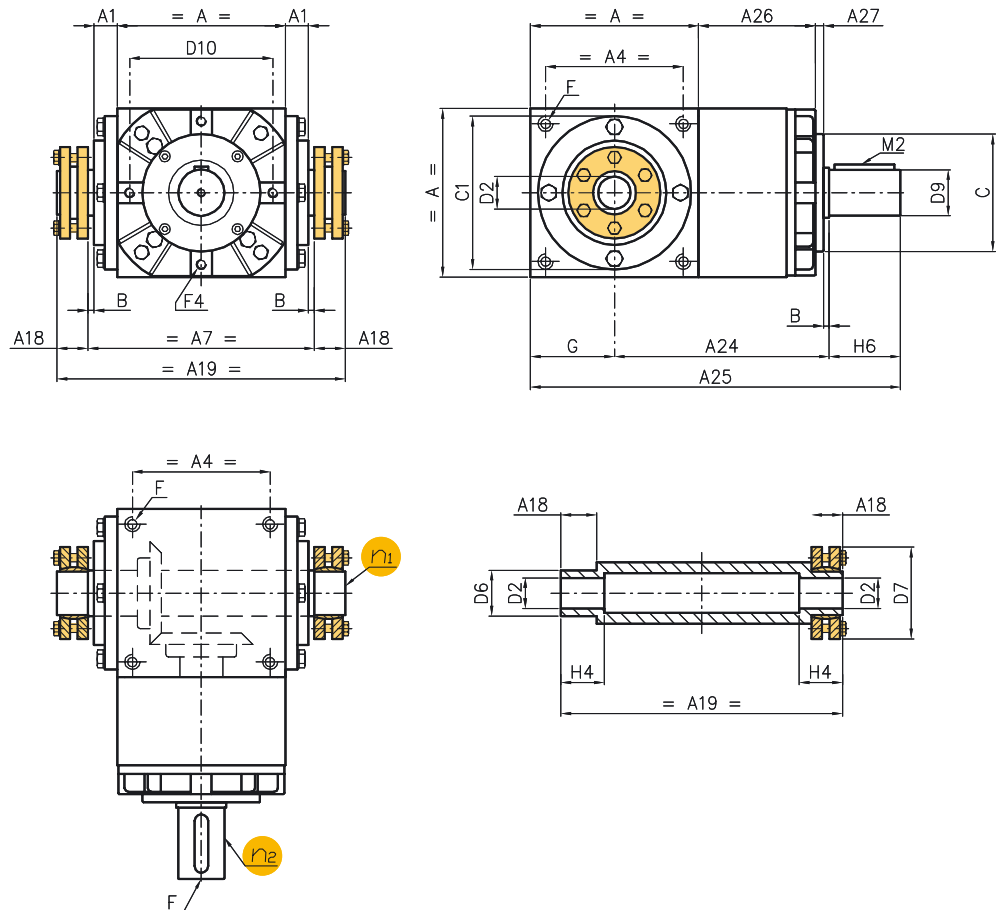

Inverted bevel gearbox with hollow shaft with shrink-disks RHA

Size	32	42	55
A	134	166	200
A1	18	21	23
A4	114	144	174
A7	174	212	250
A18	25	30	32
A24	174	203	249
A25	286	346	434
A26	97	110	139
A27	10	10	10
B	2	2	2
C $\varnothing^{-0.1}_{-0.2}$	99	116	140
C1 $\varnothing f7$	122	156	185
D2 $\varnothing H7$	24	32	42
D6 $\varnothing h7$	30	44	50
D7	60	80	90
D9 $\varnothing h7$	32	42	55
D10	116	140	170
F	M10x25	M12x30	M14x35
F3	M8x16	M10x20	M10x20
F4	M8x18	M10x20	M12x24
G	67	83	100
H4	35	45	50
H6	45	60	85
M2	10x8x40	12x8x50	16x10x70

For the characteristics of shrink-disks, make reference to RA models on page 201 (sizes 134, 166 and 200)

