

DIN 8187

## Navařovací náboj pro pouzdra TAPER-LOCK®

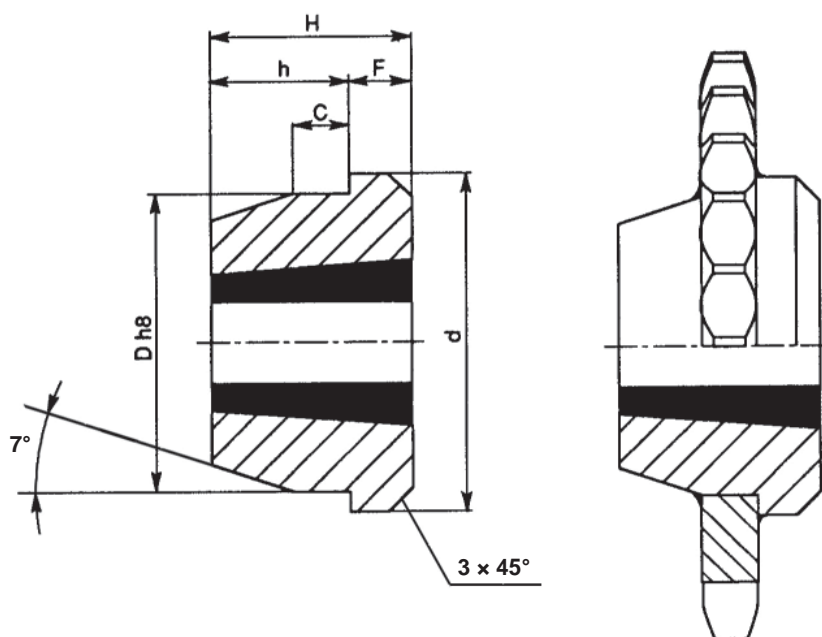

Materiál: ocel Fe 50

Typ pouzdra	Označení	d [mm]	H [mm]	C [mm]	F [mm]	h [mm]	DH8 [mm]
1210	MSB1210	73	25	10	9	16	60
1215	MSB1215	76	38	11	16	22	60
1610	MSB1610	83	25	10	9	16	70
1615	MSB1615	83	38	11	16	22	70
2012	MSB2012	96	32	12	10	22	90
2517	MSB2517	127	45	13	19	26	110
3020	MSB3020	152	51	18	24	27	130
3030	MSB3030	152	76	19	25	51	130
3525	MSB3525	184	65	25	25	40	155
3535	MSB3535	184	89	25	32	57	155
4040	MSB4040	225	102	35	32	70	195
4545	MSB4545	254	114	40	38	76	220
5050	MSB5050	276	127	40	38	89	242

Upínací pouzdra TAPER-LOCK®

DIN 8187

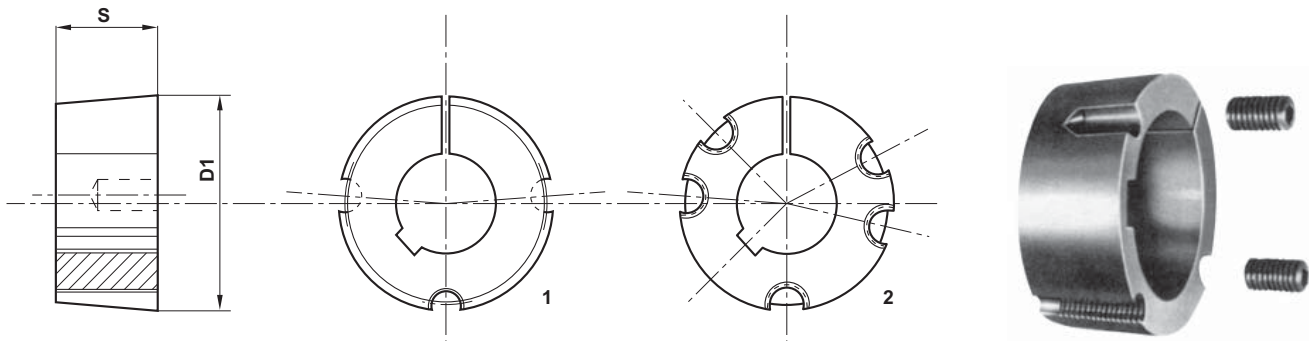

Metrická řada

Materiál: šedá litina G22

\*Příklad označení: otvor v mm Ø 14 = 1615014

Počet zubů	Označ.	Otvor s drážkou pro pero (ISO E 8) [mm]	Přenáš. kroucí moment [N/m]	B.S.W. šrouby	D1 [mm]	Typ	S [mm]	Váha [kg]
1008	1008...	9 10 11 12 14 16 18 19 20 22 24 25	136	1/4" x 1/2"	35,0	1	22,3	0,16
1108	1108...	9 10 11 12 14 16 18 19 20 22 24 25 28*	147	1/4" x 1/2"	38,0	1	22,3	0,16
1210	1210...	11 12 14 16 18 19 20 22 24 25 28 30 32	407	3/8" x 5/8"	47,5	1	25,4	0,32
1215	1215...	14 19 20 24 25 28	407	3/8" x 5/8"	47,5	1	38,1	0,50
1610	1610...	14 16 18 19 20 22 24 25 28 30 32 35 38 40* 42*	486	3/8" x 5/8"	57,0	1	25,4	0,41
1615	1615...	14 16 18 19 20 22 24 25 28 30 32 35 38 40* 42*	486	3/8" x 5/8"	57,0	1	38,1	0,60
2012	2012...	14 16 18 19 20 22 24 25 28 30 32 35 38 40 42 45 48 50*	808	7/16" x 7/8"	70,0	1	31,8	0,75
2517	2517...	16 18 19 20 22 24 25 28 30 32 35 38 40 42 45 48 50 55 60	1310	1/2" x 1"	85,5	1	44,5	1,06
3020	3020...	25 28 30 32 35 38 40 42 45 48 50 55 60 65 70 75	2710	5/8" x 1 1/4"	108,0	1	50,8	2,50
3030	3030...	35 38 40 42 45 48 50 55 60 65 70 75	2710	5/8" x 1 1/2"	108,0	1	76,2	3,75
3525	3525...	35 38 40 42 45 48 50 55 60 65 70 75 80 85	5060	1/2" x 1 1/2"	127,0	2	64,9	4,20
3535	3535...	35 38 40 42 45 48 50 55 60 65 70 75 80 100*	5060	1/2" x 1 1/2"	127,0	2	88,9	5,13
4030	4030...	40 42 45 48 50 55 60 65 70 75 80 85 90 100* 90*	8740	5/8" x 1 1/2"	146,0	2	76,2	6,75
4040	4040...	40 42 45 48 50 55 60 65 70 75 80 85 90	8740	5/8" x 1 3/4"	146,0	2	101,6	7,68
4545	4545...	55 60 65 70 75 80 85 90 100*	12400	3/4" x 2"	162,0	2	115,0	10,56
5050	5050...	70 75 80 85 90 100 105 110 115 120 125	12400	7/8" x 2 1/4"	177,6	2	127,0	15,17

Rozměry otvorů s drážkami na pero (UNI 6604-69 DIN 6885) pro metrickou řadu.

D [mm]		b [mm]	t [mm]
nad	do		
10	12	4	D + 1,8
12	17	5	D + 2,3
17	22	6	D + 2,8
22	30	8	D + 3,3
30	38	10	D + 3,3
38	44	12	D + 3,3
44	50	14	D + 3,8
50	58	16	D + 4,3
58	65	18	D + 4,4
65	75	20	D + 4,9
75	85	22	D + 5,4
85	95	25	D + 5,4
95	110	28	D + 6,4
110	130	32	D + 7,4

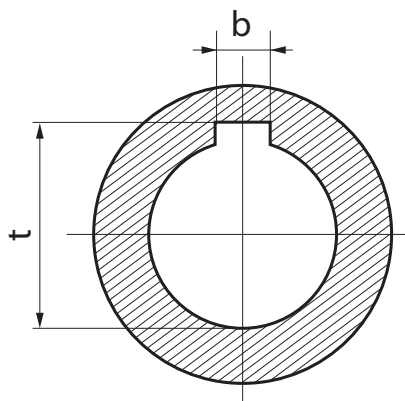

Provedení pro úzké pero

Rozměr drážky pro pero		
D* [mm]	b [mm]	t [mm]
28*	8	D + 1,3
35*	10	D + 1,3
40*/42*	12	D + 1,3
50*	14	D + 2,8
90*	25	D + 3,4
100*	28	D + 5,4

\* Na poptávku

Poznámka: Provedení v palcových mírách možné!