

**UNIMOTION**

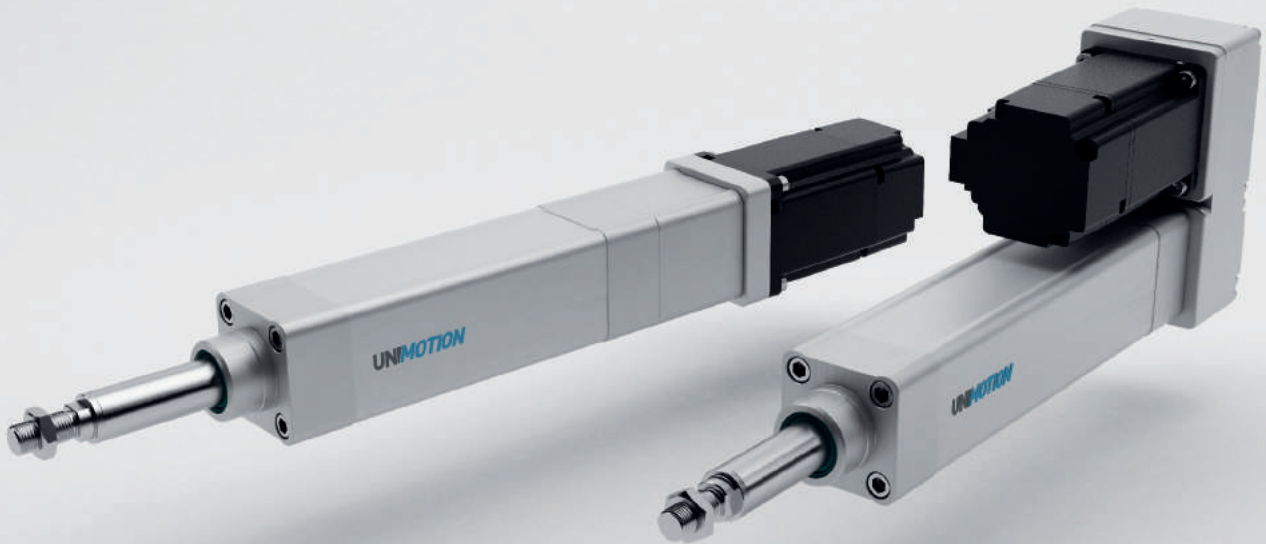

**PNCE**  
**ELECTRIC CYLINDER**



ISO  
15552

IP65

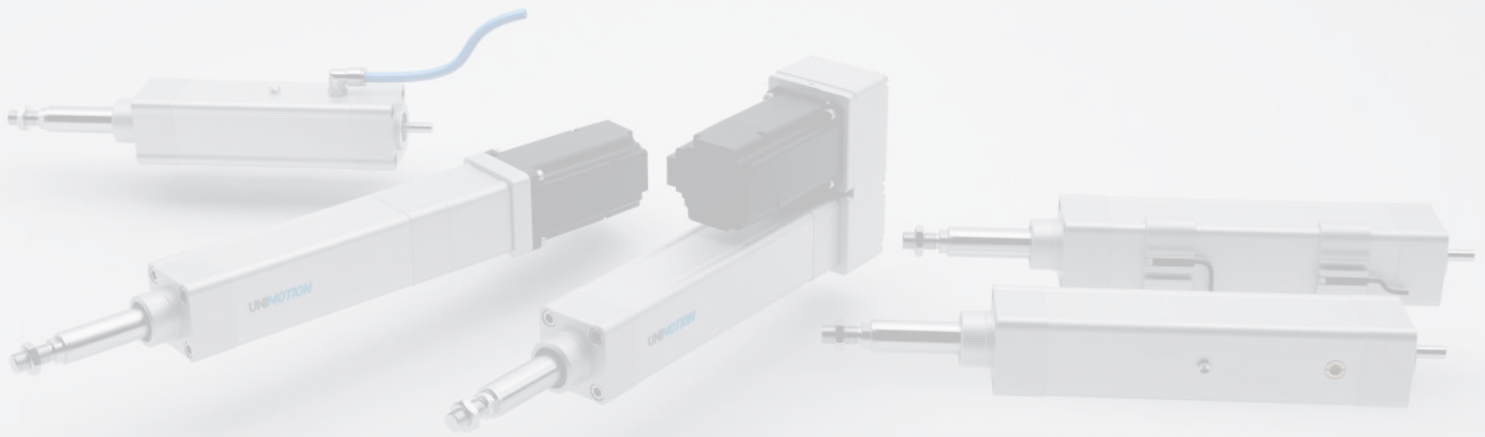

## INDEX

Characteristics	2
Structural design	3
How to order	4
Technical data	5
Dimensions	17
Accessories	18
Lubrication position	29
Motor adapter with coupling	29
Motor side drive with timing belt	30
Couplings	32
Magnetic field sensor	33
Load torque calculation and determination of maximum axial load on the PNCE cylinder	34

**CHARACTERISTICS**

The PNCE are electric cylinders with a precision ball screw drive. The electric cylinder is based on the standard ISO 15552. Its outer design and dimensions are very similar to pneumatic cylinders. High performance features such as, high speeds, good positioning accuracy and high repeatability are ensured through a precision ball screw with reduced backlash (preload on request) of the ball nut and non-rotating piston rod. For a long service life the re-lubrication can be done through a lubrication nipple. The design with its smooth surfaces enables easy cleaning of the cylinder. In combination with a lubricant class H1 it is also suitable for food & beverage applications. It can be additionally equipped with switches and ISO standard accessories.

The excellent sealing of the components in the cylinder ensures an IP65 protection class and protects the interior of the cylinder from dust, water and other contaminants. Version IP65CR also offers a high corrosion resistance in harsh environments.



The aluminium profiles are manufactured according to the medium EN 12020-2 standard

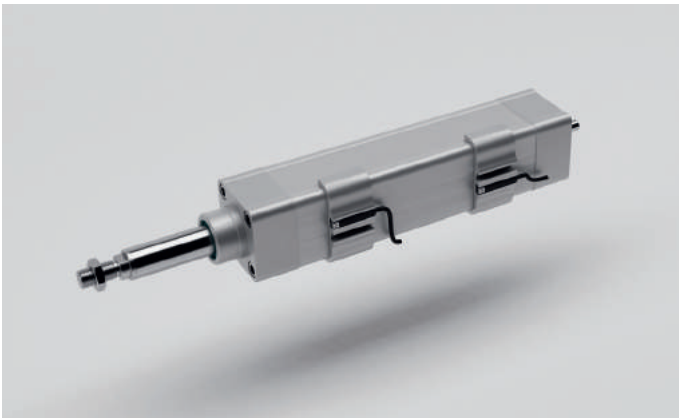

Sensor holder

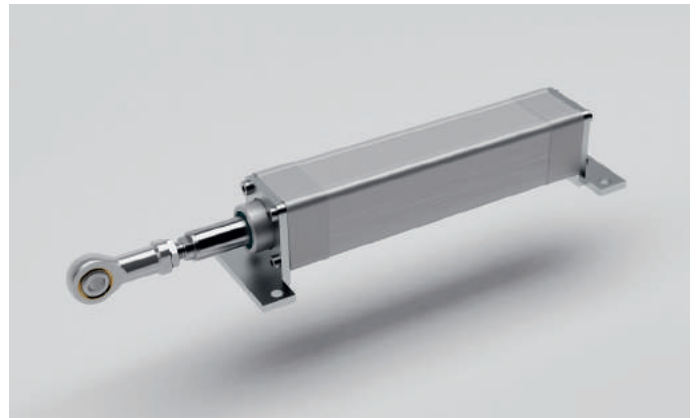

ISO standard accessories

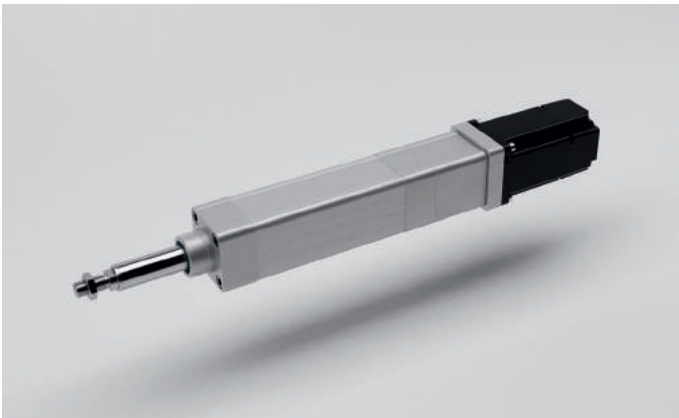

Motor adapter with coupling (IP65)

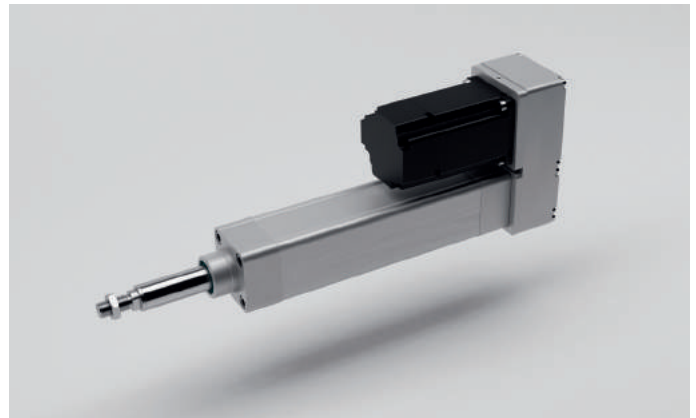

Motor side drive (IP65)

STRUCTURAL DESIGN

• Standard version (S)\*

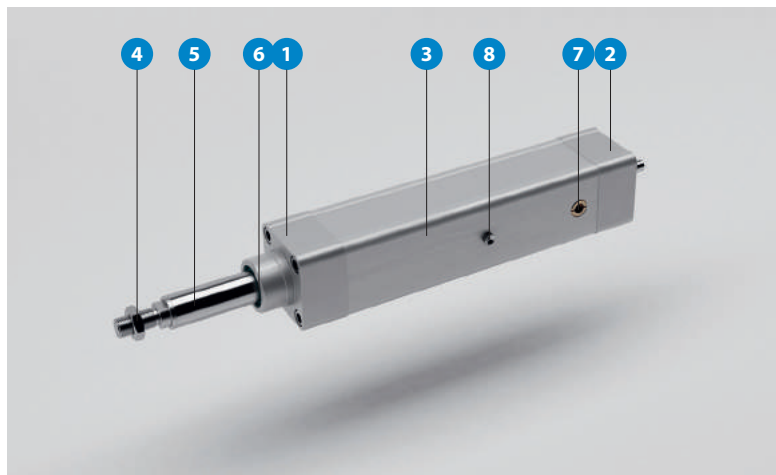

- 1 – Front cap
- 2 – Drive cap
- 3 – Smooth cylinder profile
- 4 – Hex nut
- 5 – Piston rod (stainless steel) with an anti-rotation device
- 6 – Piston rod seal
- 7 – Pressure compensation
- 8 – Lubrication nipple

\* IP40 protection class

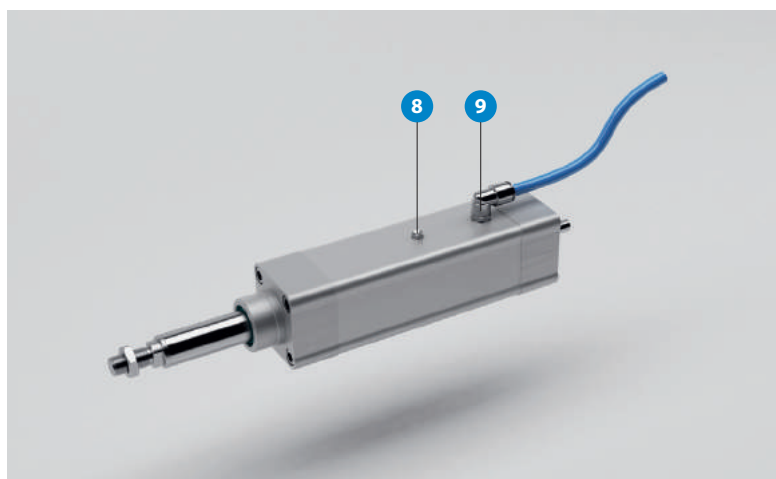

- 8 – Lubrication nipple
- 9 – Connection for pressure compensation

• IP65 protection class (IP65)



The appropriate sealing of the external parts ensures the electric cylinder the IP65 protection class. The IP65 protection class of the electric cylinder fulfils the specifications to IEC 60 529. The connection for pressure compensation in the cylinder profile ensures the exchange of air between the interior of the cylinder and the environment. This prevents the occurrence of excess pressure or negative pressure inside the electric cylinder. It also protects the interior of the cylinder from the external media like dust and water.

• IP65 protection class with high corrosion resistance (IP65CR)



It offers high corrosion resistance in harsh environments. The version IP65CR includes all the features of the electric cylinder version IP65. In addition to ensuring high corrosion resistance all the external parts are corrosion resistant (e.g. the connection for pressure compensation, lubrication nipple, and the connection elements are made of stainless steel). More information about materials is available upon request in the extended material information list.

• For applications in the food industry (FI)



The version FI includes all the features of the electric cylinder version IP65CR. It is upgraded by materials suitable for some applications in the food industry. The cylinder is greased with a lubricant class NSF H1. The design with the smooth surfaces of the aluminium profile enables its quick and effective cleaning. During the cleaning the sealing air can be applied to the connection for pressure compensation. The use for the food & beverage industry is limited by the materials of the electric cylinder. More information about materials is available upon request in the extended material information list.

## HOW TO ORDER

PNCE - 40 - BS - 1610 - 200 - S - F - E20

**Series:** \_\_\_\_\_

PNCE

**Size:** \_\_\_\_\_

- 32
- 40
- 50
- 63
- 80
- 100

**Screw type:** \_\_\_\_\_

- BS: ball screw

**Ball screw:** \_\_\_\_\_

- PNCE 32: Ø12x5, Ø12x10
- PNCE 40: Ø16x5, Ø16x10, Ø16x16
- PNCE 50: Ø20x5, Ø20x10, Ø20x20, Ø20x50
- PNCE 63: Ø25x5, Ø25x10, Ø25x25
- PNCE 80: Ø32x5, Ø32x10, Ø32x20, Ø32x32
- PNCE 100: Ø40x5, Ø40x10, Ø40x20, Ø40x40

**Absolute stroke [mm]:** \_\_\_\_\_

Absolute stroke = Effective stroke + 2 × Safety stroke

**Versions:** \_\_\_\_\_

- S: Standard version
- IP65: IP65 protection class
- IP65CR: IP65 protection class with high corrosion resistance
- FI: For applications in the food industry (check the material information)

**Option 1:** \_\_\_\_\_

- Leave blank: standard
- F: female thread on the piston rod

**Option 2:** \_\_\_\_\_

- Extended piston rod E [mm]

## TECHNICAL DATA

### General technical data for the PNCE series

PNCE	Ball screw	Dynamic * load capacity	Maximum axial load **	Maximum drive torque	Maximum travel speed ***	Max. rotational speed	No load torque	Minimum stroke	Maximum stroke	Axial backlash (BS)	Maximum acceleration
	d×l [mm]	C [N]	F <sub>max</sub> [N]	M <sub>p</sub> [Nm]	v <sub>max</sub> [m/s]	n <sub>max</sub> [min <sup>-1</sup> ]	M <sub>0</sub> [Nm]	s <sub>min</sub> [mm]	s <sub>max</sub> [mm]	[mm]	[m/s <sup>2</sup> ]
32	12×5	5000	2540	2,2	0,48	5800	0,10	30	800	< 0,02	20
	12×10	3800	1270		0,97		0,15	30			
40	16×5	13150	6020	5,3	0,35	4200	0,15	40	900	< 0,02	20
	16×10	11550	3010		0,70		0,20	35			
	16×16	8170	1880		1,12		0,25	35			
50	20×5	14800	14600	12,9	0,28	3300	0,30	50	1000	< 0,02	20
	20×10	15900	7830	13,9	0,55		0,35	55			
	20×20	16250	3900		1,10	0,40	50				
	20×50	13000	1560	2,5	3000	0,50	30				
63	25×5	16700	16500	14,6	0,23	2700	0,50	40	1200	< 0,02	20
	25×10	15800	15800	28,0	0,45		0,55	40			
	25×25	16700	7940	35,1	1,13		0,65	30			
80	32×5	18850	18850	16,7	0,18	2150	0,65	60	1500	< 0,02	20
	32×10	37000	25000	44,2	0,50	3000	0,70	60			
	32×20	22950	17160	60,7	1,00		0,75	70			
	32×32	15500	10725	60,7	1,60		0,90	70			
100	40×5	23800	23800	21,0	0,18		2200	1,00	45	1500	< 0,02
	40×10	38000	29000	51,3	0,37	1,10		55			
	40×20	33300	29000	102,6	0,73	1,20		65			
	40×40	35000	22980	162,6	1,47	1,40		80			

\* Dynamic load capacity of ball screw drive. This value is the basis for calculating the service life.

\*\* When considering service life, see page 15. This value needs to be considered when using the piston rod or mounting attachments' accessories.

\*\*\* Maximum travel speed depends of the absolute stroke of the PNCE, see diagrams on page 11.

### Operating conditions

Operating temperature	0°C ~ +60°C
Protection class	IP40, IP65
Duty cycle	100 %

#### **i** Recommended values of loads:

All the data of the dynamic load capacities (ball screw drive) stated in the upper table are theoretical without considering any safety factor. The safety factor depends on the application and its requested safety and service life.

We recommend a minimum safety factor  $f_s = 5,0$ , where  $f_s$  is defined as  $f_s = C / F_m$ .

See page 15 for information on how the applied mean axial load  $F_m$  affects the service life.

### Mass and mass moment of inertia

PNCE	Ball screw	Moved mass *	Mass of the electric cylinder	Mass moment of inertia
	d×l [mm]	m <sub>m</sub> [kg]	m <sub>PNCE</sub> [kg]	J <sub>PNCE</sub> [10 <sup>-6</sup> kg m <sup>2</sup> ]
32	12×5	0,32 + 0,0010 × (Absolute stroke + E)	1,10 + 0,0043 × Absolute stroke + 0,0010 × E	2,15 + 0,0128 × Absolute stroke + 0,0006 × E + 0,6333 × m <sub>load</sub>
	12×10			2,75 + 0,0147 × Absolute stroke + 0,0025 × E + 2,5330 × m <sub>load</sub>
40	16×5	0,44 + 0,0007 × (Absolute stroke + E)	1,45 + 0,0051 × Absolute stroke + 0,0007 × E	4,50 + 0,0395 × Absolute stroke + 0,0004 × E + 0,6333 × m <sub>load</sub>
	16×10			5,35 + 0,0408 × Absolute stroke + 0,0018 × E + 2,5330 × m <sub>load</sub>
	16×16			7,10 + 0,0436 × Absolute stroke + 0,0046 × E + 6,4846 × m <sub>load</sub>
50	20×5	0,95 + 0,0012 × (Absolute stroke + E)	2,50 + 0,0073 × Absolute stroke + 0,0012 × E	17,75 + 0,0817 × Absolute stroke + 0,0007 × E + 0,6333 × m <sub>load</sub>
	20×10			19,55 + 0,0839 × Absolute stroke + 0,0030 × E + 2,5330 × m <sub>load</sub>
	20×20			26,75 + 0,0928 × Absolute stroke + 0,0118 × E + 10,1321 × m <sub>load</sub>
	20×50			73,80 + 0,1549 × Absolute stroke + 0,0740 × E + 63,3257 × m <sub>load</sub>
63	25×5	1,00 + 0,0011 × (Absolute stroke + E)	3,05 + 0,0097 × Absolute stroke + 0,0011 × E	32,55 + 0,2358 × Absolute stroke + 0,0007 × E + 0,6333 × m <sub>load</sub>
	25×10			34,45 + 0,2378 × Absolute stroke + 0,0028 × E + 2,5330 × m <sub>load</sub>
	25×25			47,30 + 0,2523 × Absolute stroke + 0,0172 × E + 15,8314 × m <sub>load</sub>
80	32×5	2,15 + 0,0028 × (Absolute stroke + E)	6,48 + 0,0156 × Absolute stroke + 0,0028 × E	118,14 + 0,6514 × Absolute stroke + 0,0018 × E + 0,6333 × m <sub>load</sub>
	32×10			122,23 + 0,6567 × Absolute stroke + 0,0071 × E + 2,5330 × m <sub>load</sub>
	32×20			138,60 + 0,6781 × Absolute stroke + 0,0285 × E + 10,1321 × m <sub>load</sub>
	32×32			172,65 + 0,7227 × Absolute stroke + 0,0731 × E + 25,9382 × m <sub>load</sub>
100	40×5	3,21 + 0,0047 × (Absolute stroke + E)	10,12 + 0,0245 × Absolute stroke + 0,0047 × E	342,17 + 1,6613 × Absolute stroke + 0,0030 × E + 0,6333 × m <sub>load</sub>
	40×10			348,27 + 1,6701 × Absolute stroke + 0,0118 × E + 2,5330 × m <sub>load</sub>
	40×20			372,67 + 1,7056 × Absolute stroke + 0,0473 × E + 10,1321 × m <sub>load</sub>
	40×40			483,41 + 1,8476 × Absolute stroke + 0,1893 × E + 40,5285 × m <sub>load</sub>

\* The moved mass is already considered in the equation for calculating the mass of the electric cylinder m<sub>PNCE</sub> and the mass moment of inertia J<sub>PNCE</sub>. The moved mass includes the mass of the piston rod with the internal anti-rotation device and ball nut.

m <sub>load</sub>	Applied mass to be moved	[kg]
E	Extended piston rod	[mm]
Absolute stroke		[mm]



**Maximum axial loading as a function of the travel speed for different values of absolute stroke**

( $F_{max}$  - v curves)

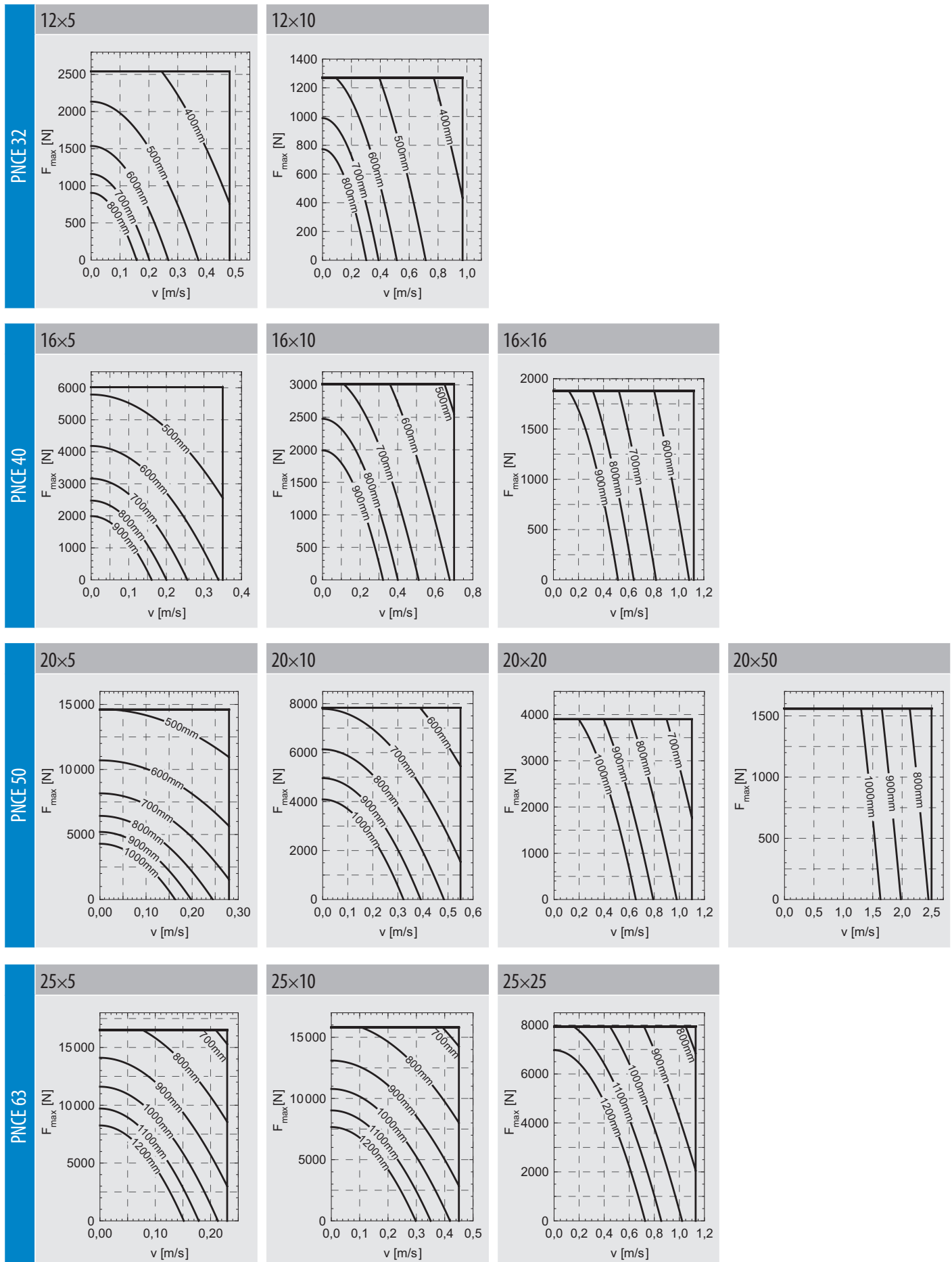

PNCE 80

32x5

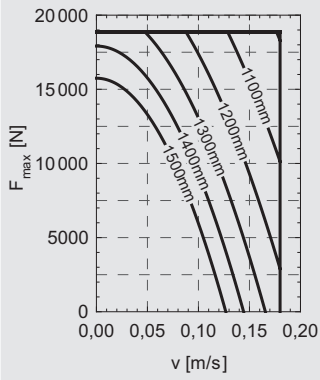

32x10

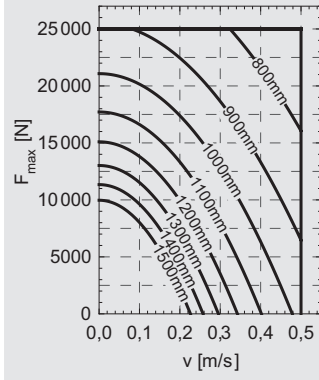

32x20

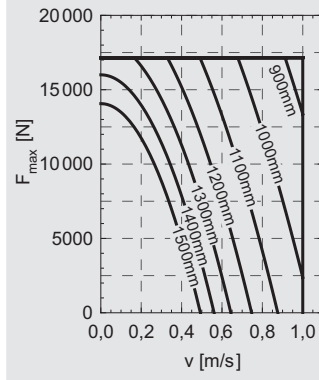

32x32

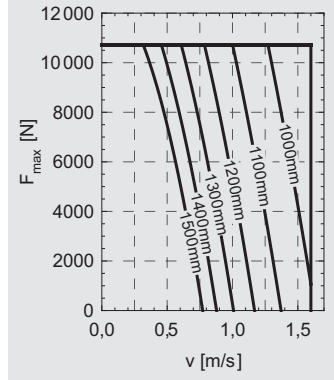

PNCE 100

40x5

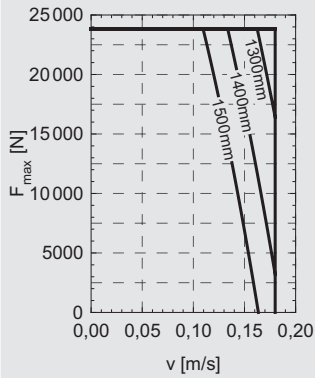

40x10

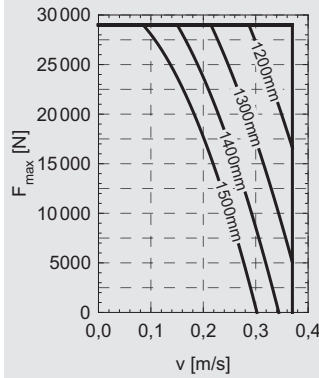

40x20

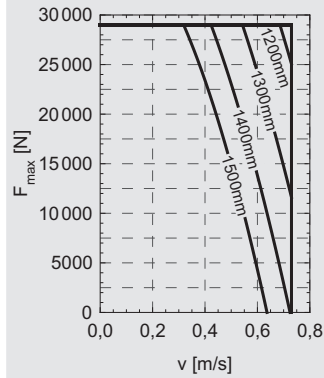

40x40

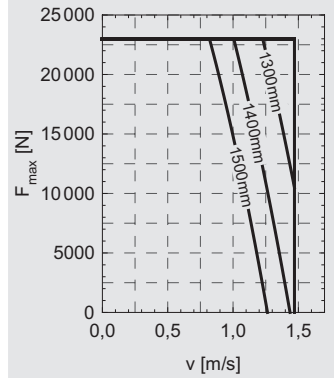

**Maximum axial loading as a function of the absolute stroke ( $F_{max}$  - absolute stroke curves)**

**Schematically presented mounting cases**

Simple - Simple mount

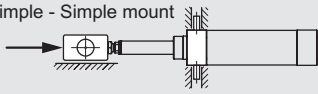

Fixed - Simple mount

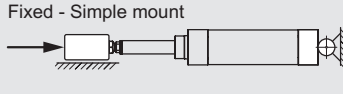

Simple - Simple mount

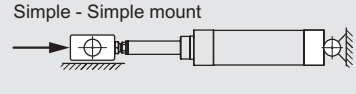

Simple - Fixed mount

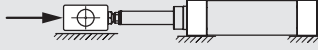

Simple - Fixed mount

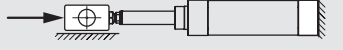

Free - Fixed mount

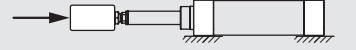

PNCE 32

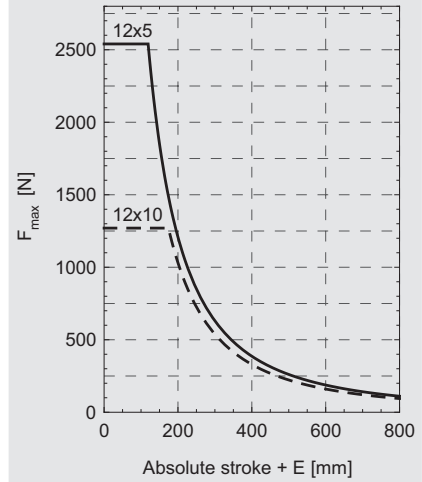
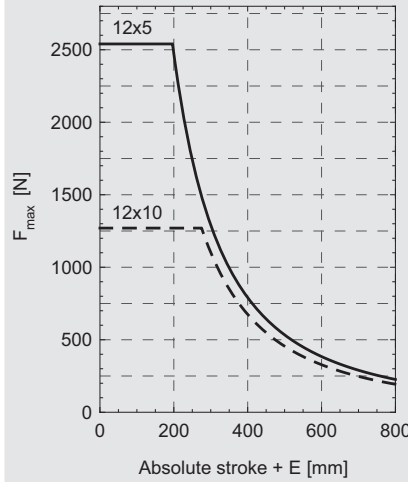
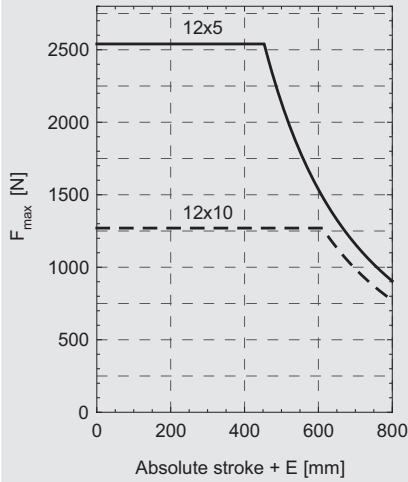

PNCE 40

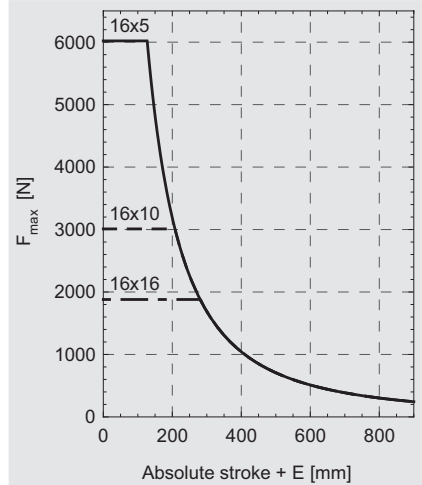
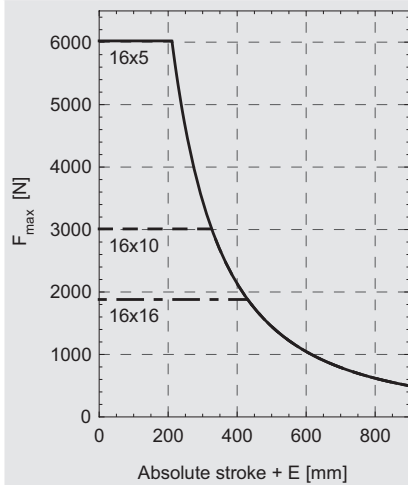
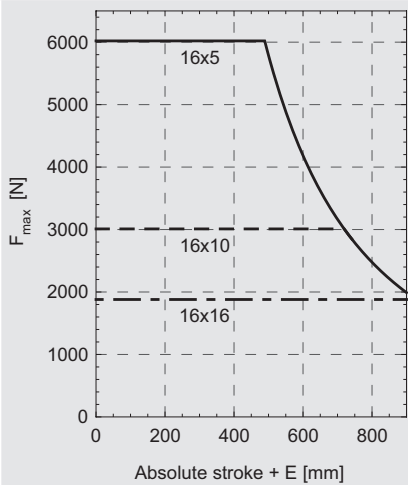

PNCE 50

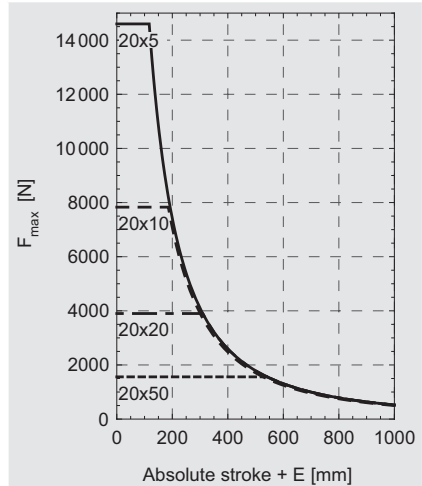
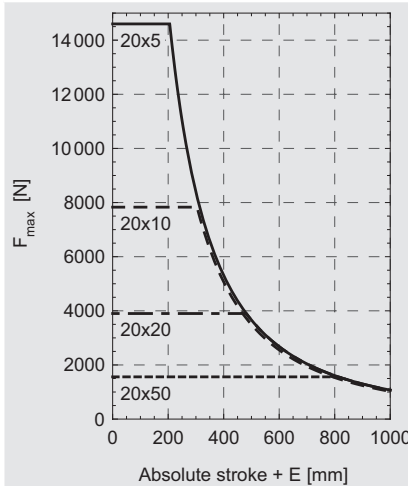
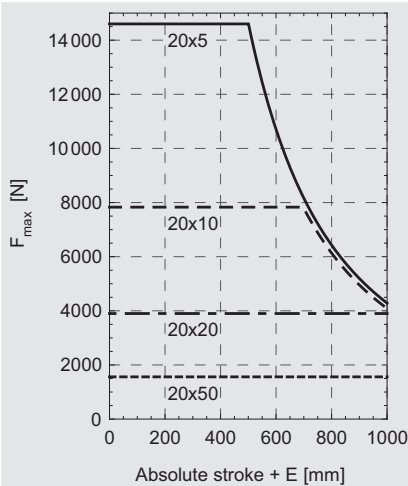

**E** Extended piston rod [mm]

**Schematically presented mounting cases**

Simple - Simple mount

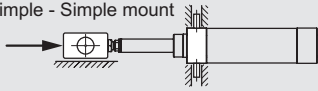

Simple - Fixed mount

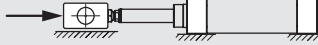

Fixed - Simple mount

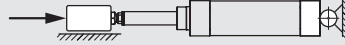

Simple - Fixed mount

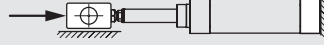

Simple - Simple mount

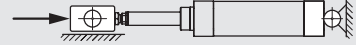

Free - Fixed mount

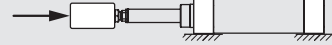

PNCE 63

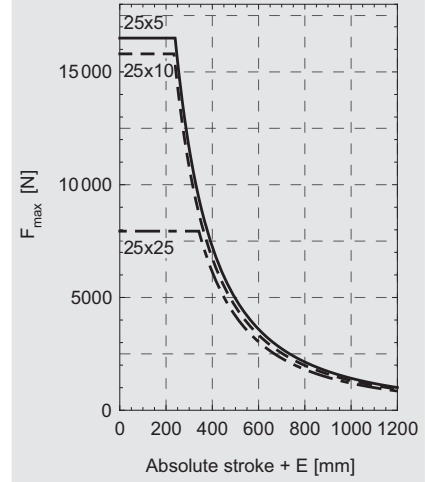
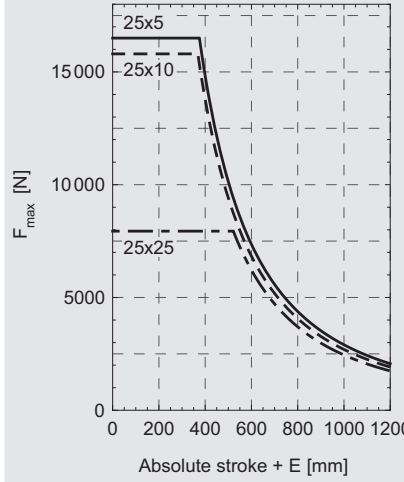
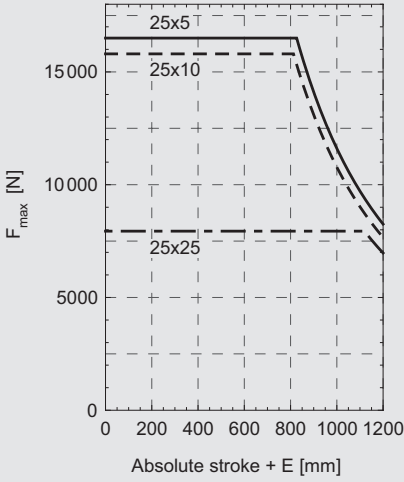

PNCE 80

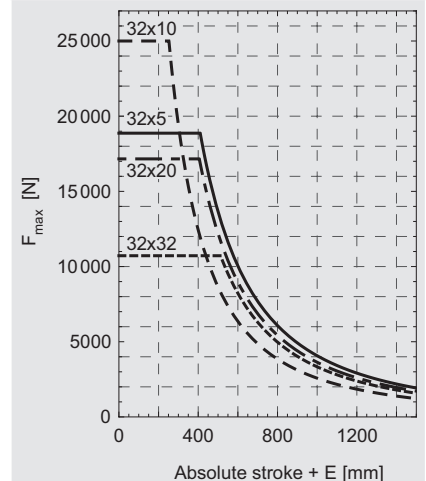
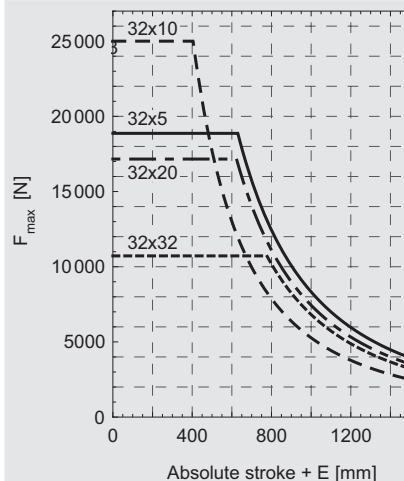
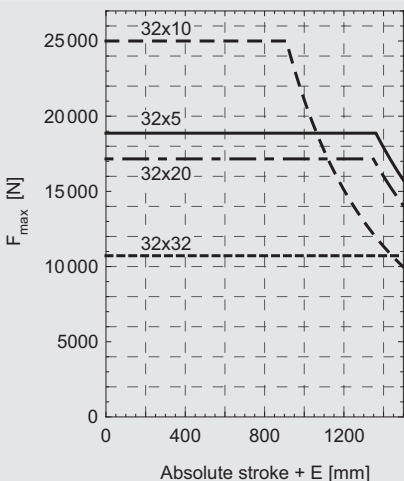

PNCE 100

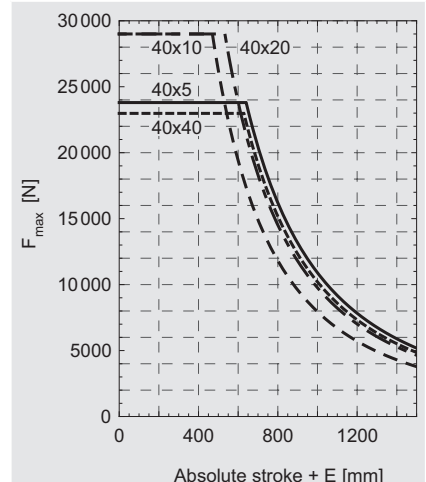
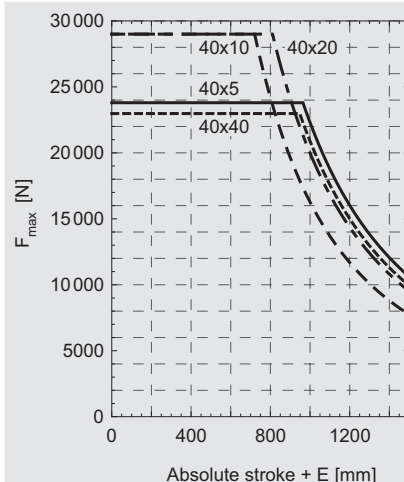
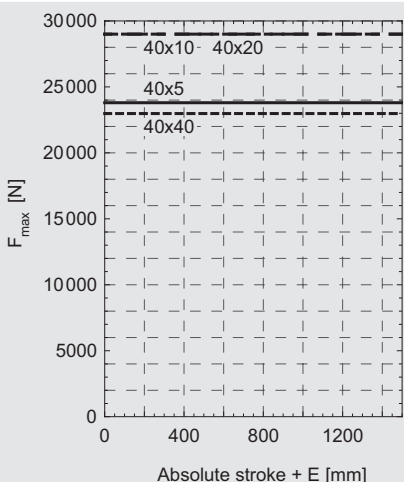

**E** Extended piston rod [mm]

**Maximum travel speed as a function of the absolute stroke ( $v_{max}$  - absolute stroke curves)**

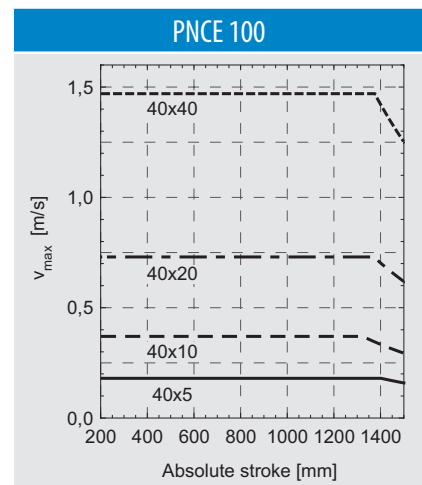
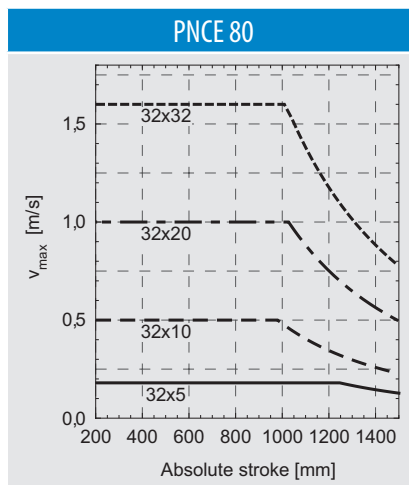
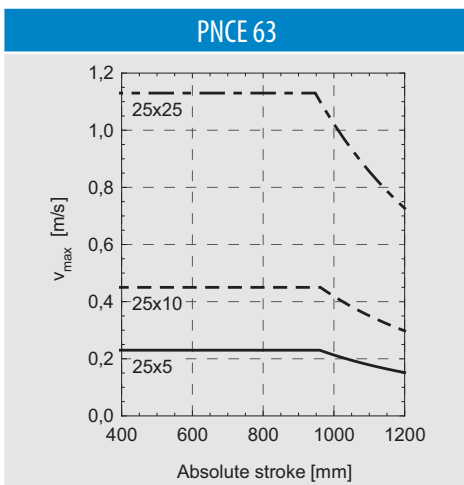
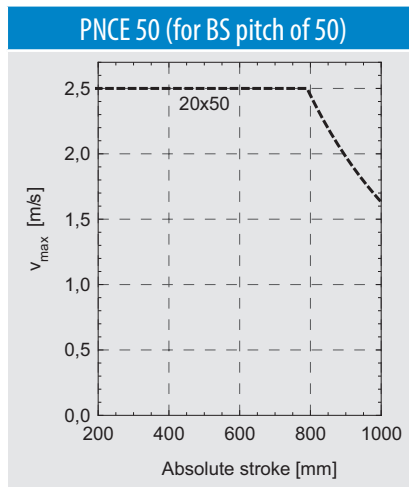
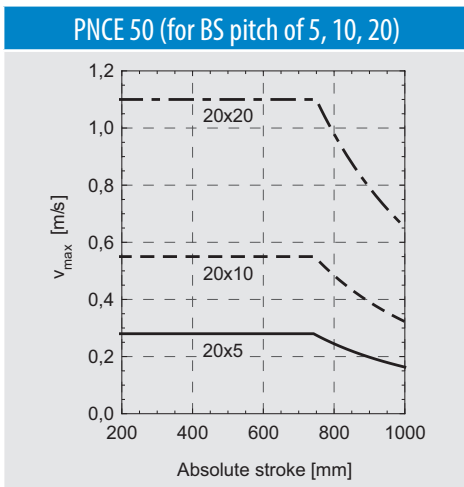
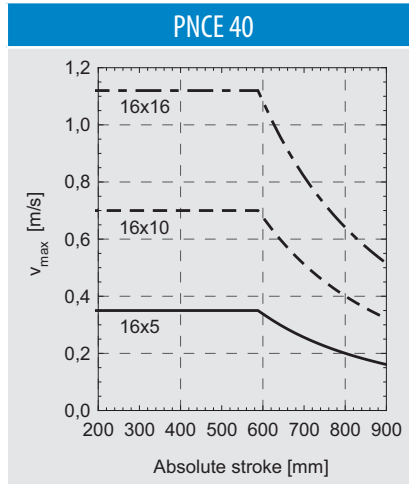
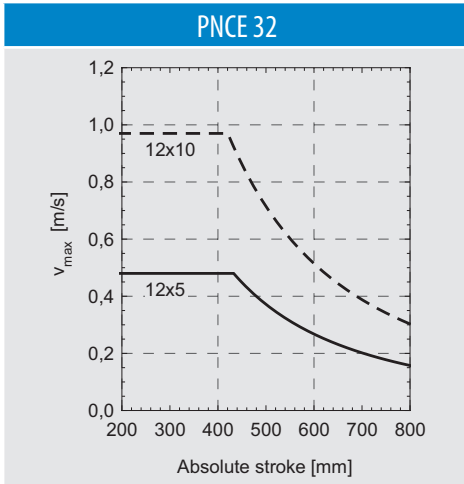

## Maximum lateral loading as a function of the piston rod position for different values of the absolute stroke ( $F_{lateral}$ - piston rod position curves)

### PNCE 32

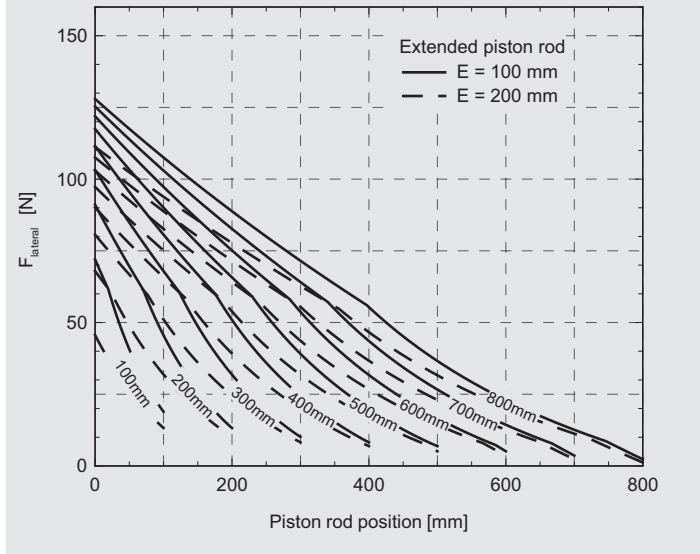
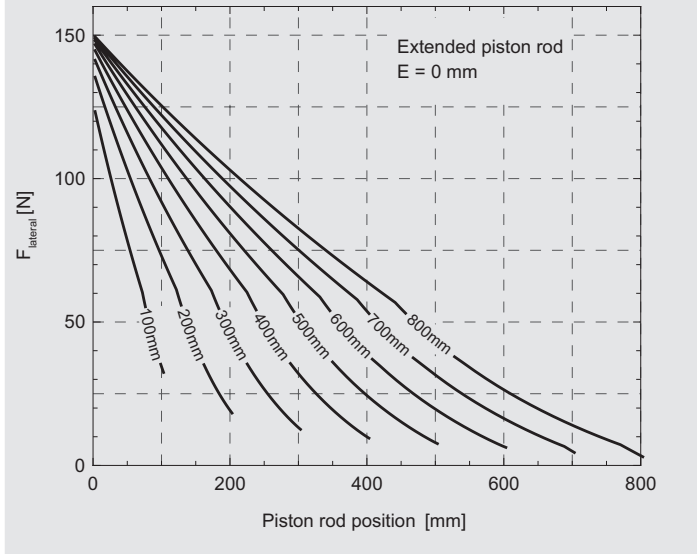

### PNCE 40

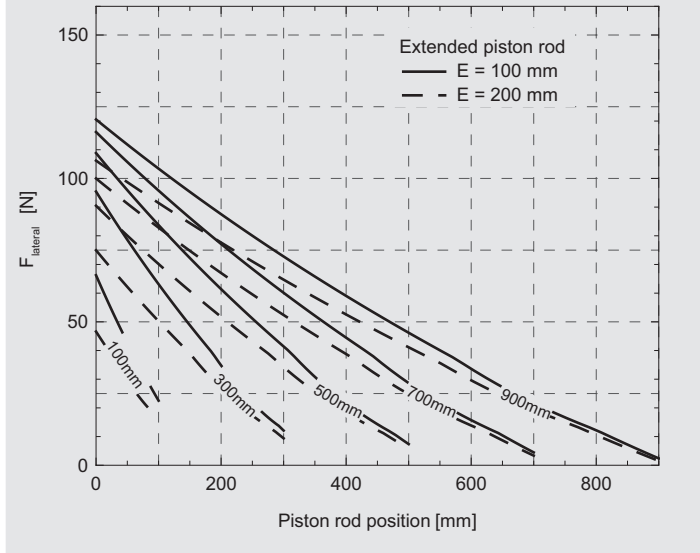
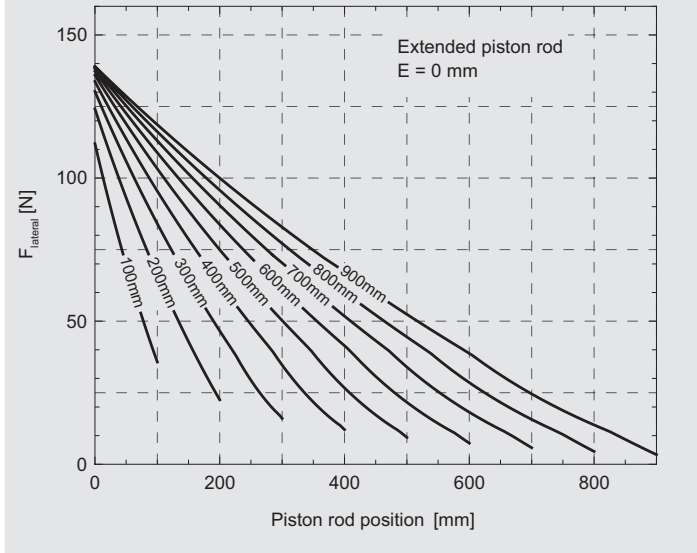

Values on the curves represent the absolute stroke

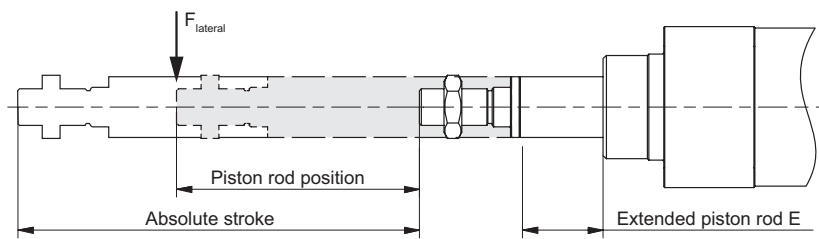

Diagrams taking into consideration a travel speed of 0,5 m/s and an axial load of  $F_{max}/4$ .

**PNCE 50**

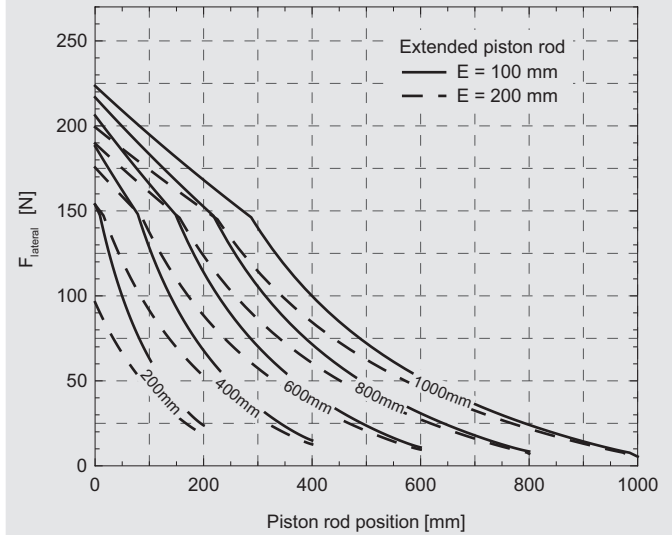
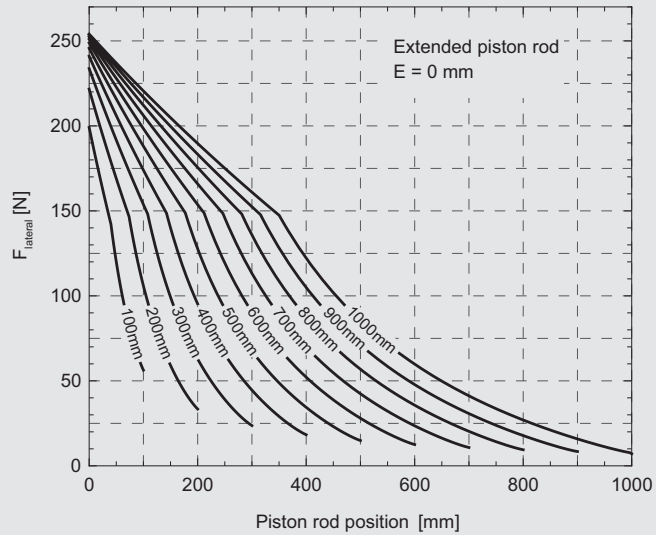

**PNCE 63**

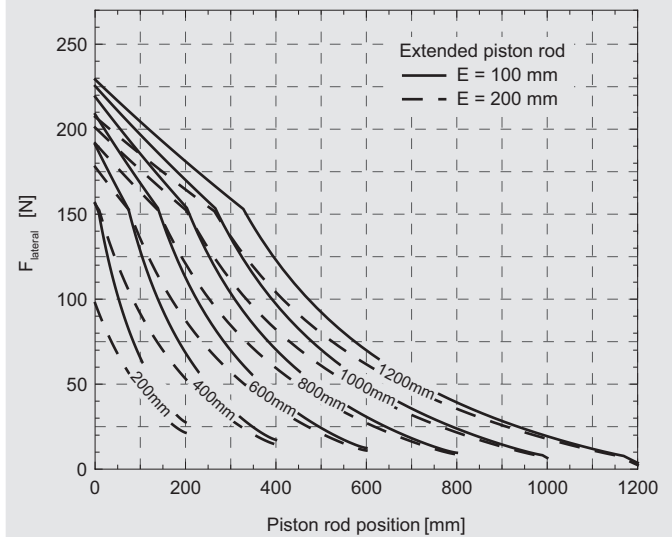
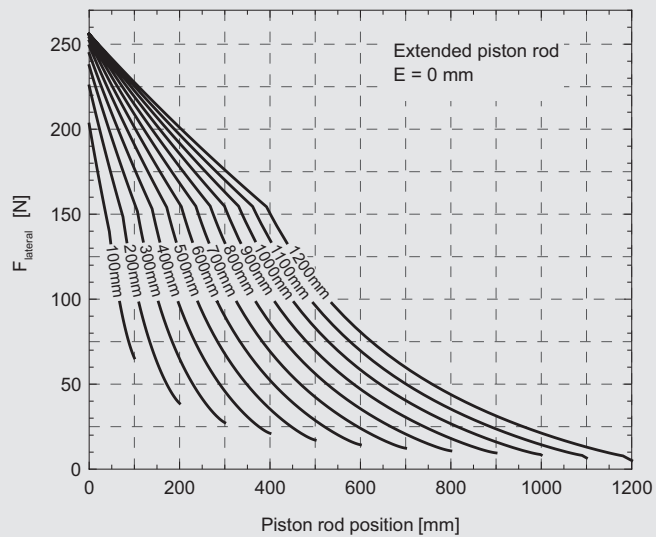

Values on the curves represent the absolute stroke

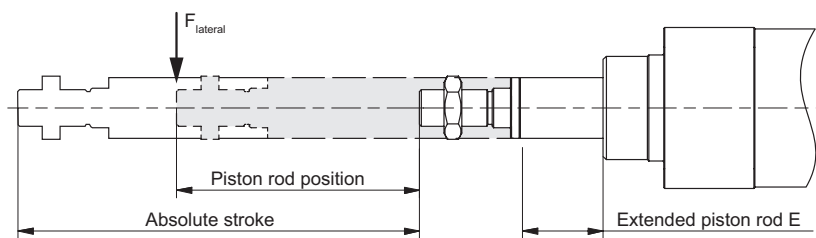

Diagrams taking into consideration a travel speed of 0,5 m/s and an axial load of  $F_{max}/4$ .

### PNCE 80

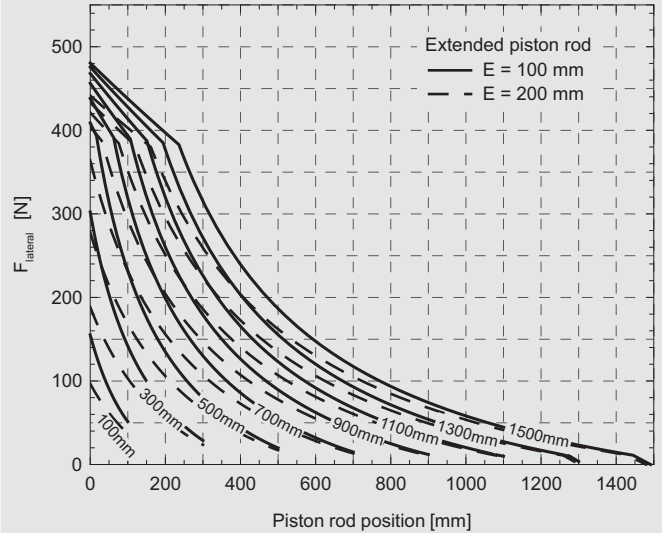
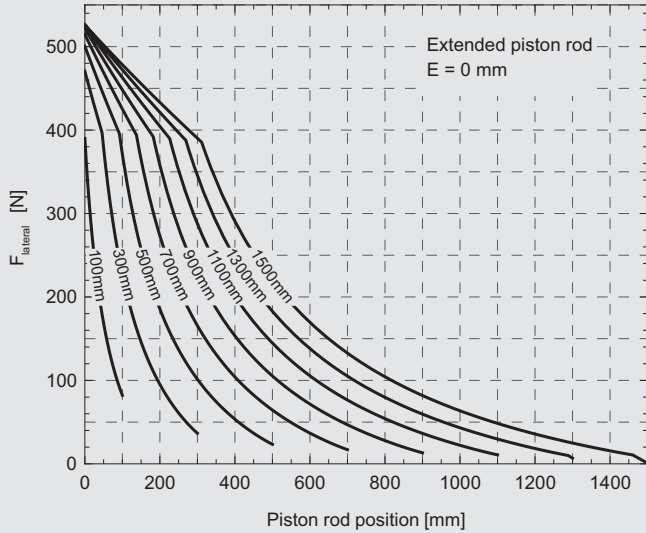

### PNCE 100

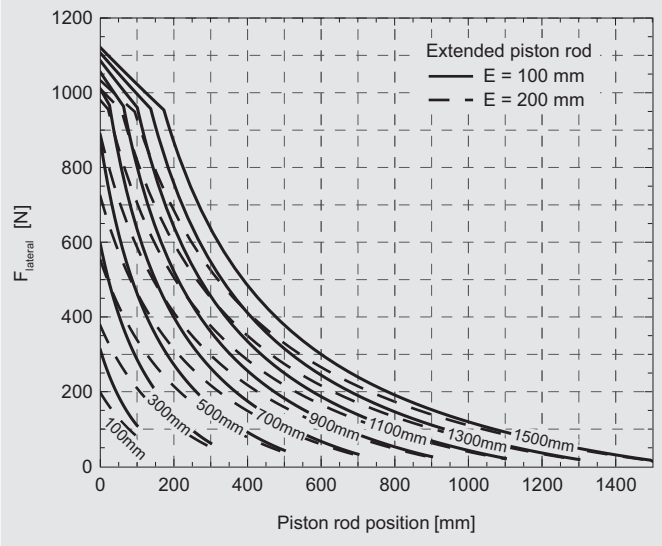
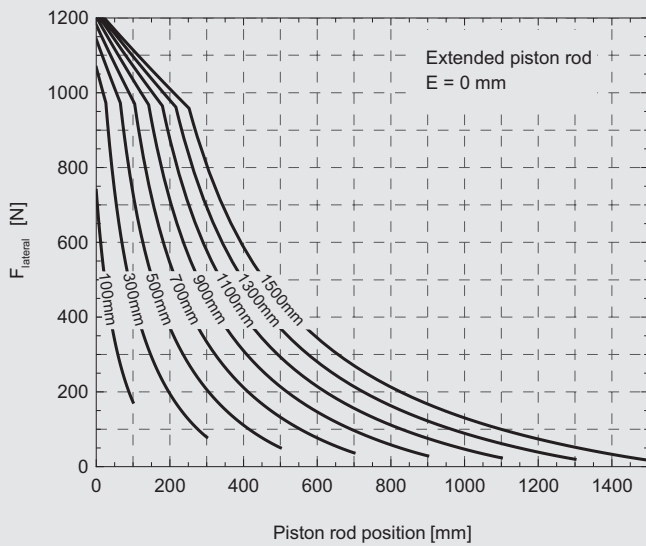

Values on the curves represent the absolute stroke

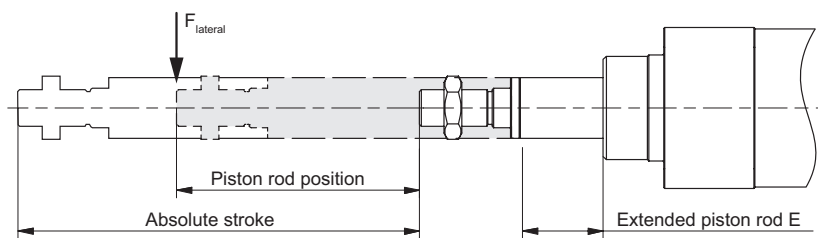

Diagrams taking into consideration  
a travel speed of 0,5 m/s and an axial load of  $F_{max}/4$ .



Service life - applied mean axial load  $F_m$  as a function of the service life  $L_{km}$

**PNCE 32**

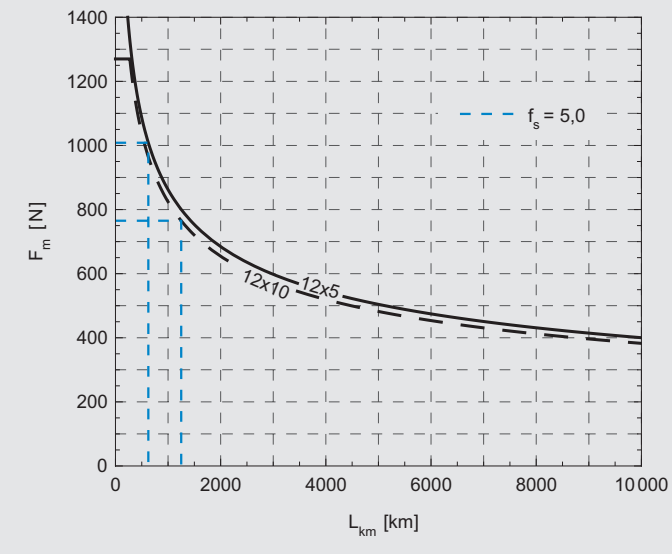

**PNCE 40**

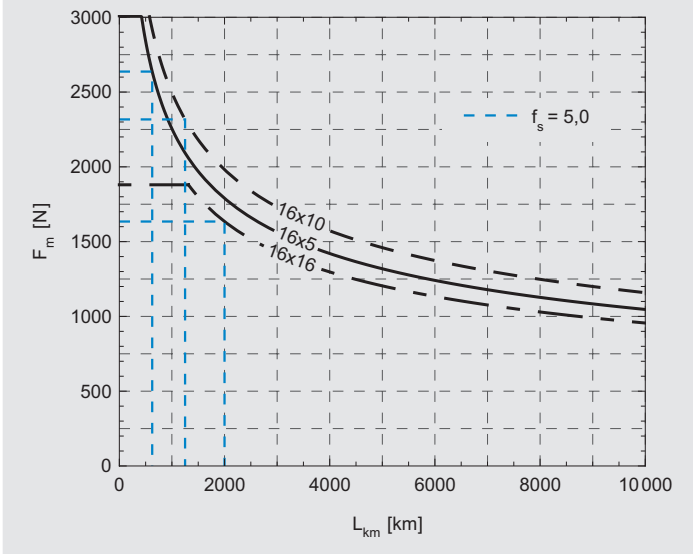

**PNCE 50**

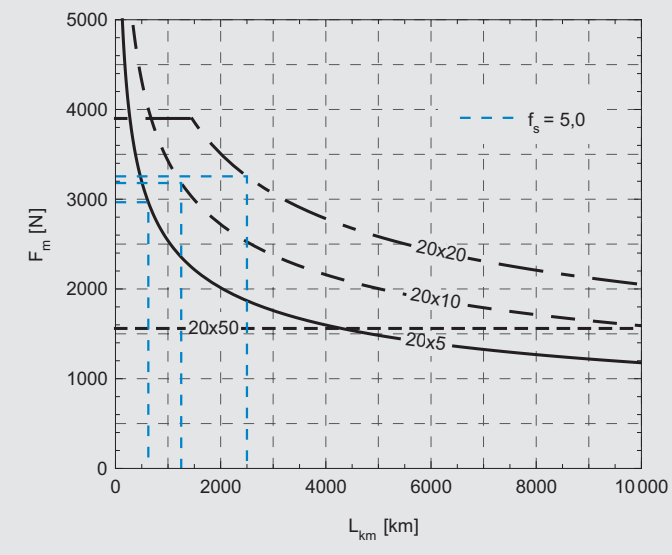

**PNCE 63**

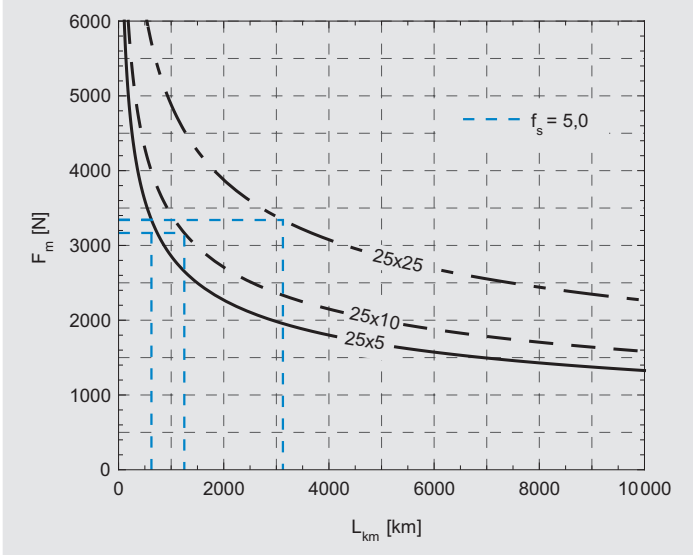

**PNCE 80**

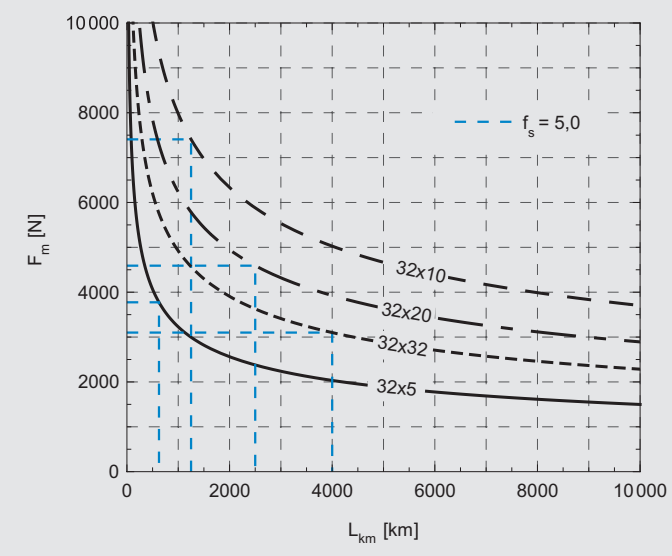

**PNCE 100**

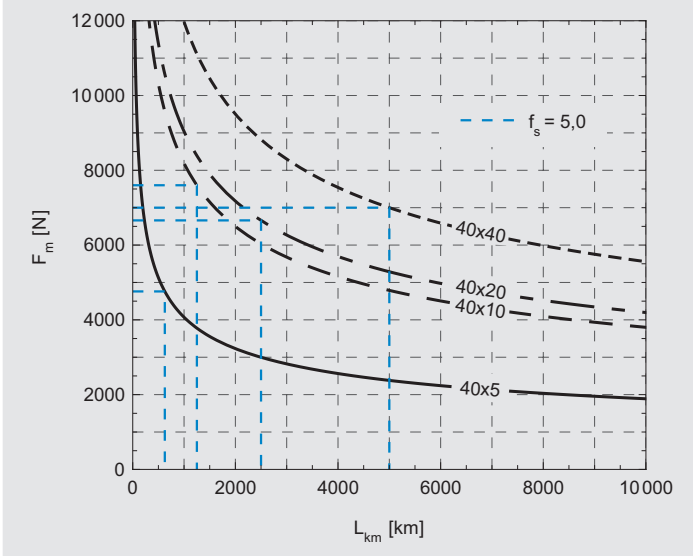

**Mean axial load  $F_m$  calculation**

$$F_m = \sqrt[3]{\frac{|F_1|^3 \times s_1 + |F_2|^3 \times s_2 + \dots + |F_n|^3 \times s_n}{s_1 + s_2 + \dots + s_n}}$$

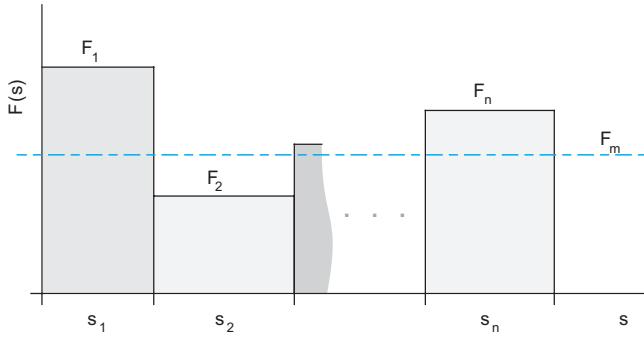

$F_m$	Mean axial load	[N]
$F_i$	i-th axial load of a given loading regime $F(s)$ , $i \in \{1, 2, \dots, n\}$	[N]
$s_i$	i-th travel path of a given loading regime $F(s)$ , $i \in \{1, 2, \dots, n\}$	[mm]

Diagrams presented on the page 15 are showing the theoretically determined service life of the ball screw drive when the mean axial load  $F_m$  at room temperature is taken into consideration.

It should be noted that application conditions may have a significant effect on the service life.

**DIMENSIONS**

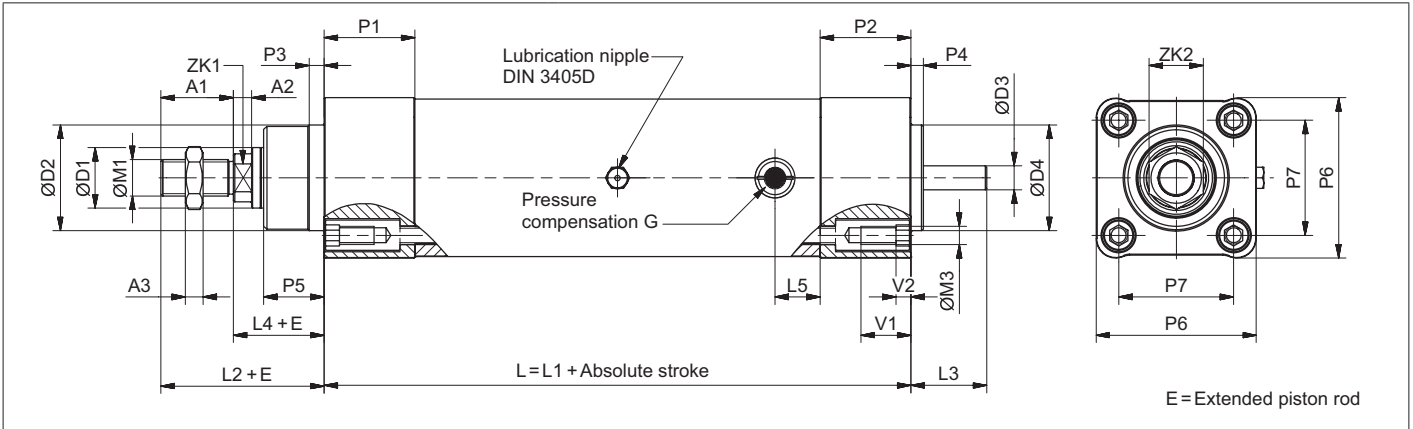

**Female thread**

**IP65, IP65CR, FI**

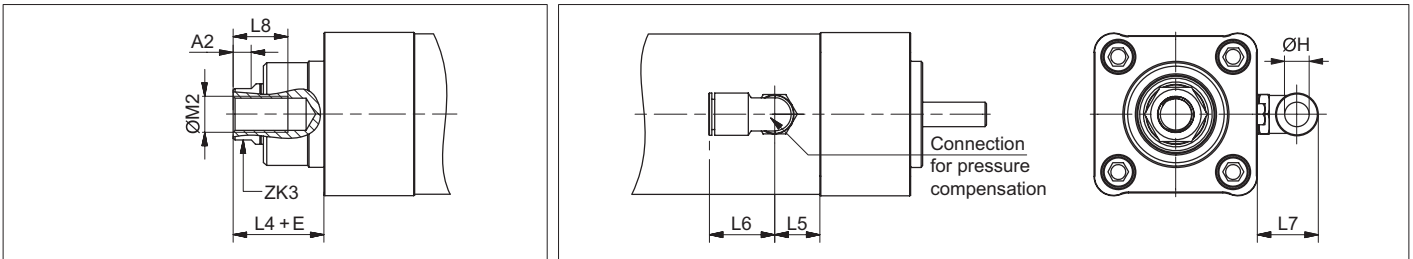

PNCE	L1 (+0,2 / -1,4)	L2	L3	L4 (+1,9 / -0,8)	L5	L6	L7	L8	P1	P2	P3	P4 (±0,1)	P5 (±0,1)	P6	P7	G
Size	[mm]															
32	136	48	21	26	15	22,5	20,0	15	30	30	5	4	18	47	32,5	G 1/8
40	144	54	25	30	15	22,5	20,0	18	30	30	5	4	20	54	38	G 1/8
50	180	69	32	37	15	22,5	20,0	25	36	37	5	4	25	65	46,5	G 1/8
63	171	69	38	37	15	22,5	20,0	25	38	38	5	4	25	75	56,5	G 1/8
80	204	86	40	46	15	22,5	20,0	30	40	40	18	14	31	93	72	G 1/8
100	224 [239]	91	50	51	25	28,5	28,0	30	42	42	20	18	34	110	89	G 3/8

PNCE	ØD1 (f8)	ØD2 (d11)	ØD3 (h7)	ØD4 (g7)	ØM1	ØM2	ØM3	ØH	A1	A2	A3	ZK1	ZK2	ZK3	V1	V2
Size	[mm]															
32	18	30	6	30	M10x1,25	M6	8	8	22	5	5	10	17	16	16	4,5
40	20	35	8	35	M12x1,25	M6	8	8	24	6	6	13	19	17	16	4,5
50	25	40	11	40	M16x1,5	M8	8	8	32	8	8	17	24	22	18	4,5
63	30	45	15	45	M16x1,5	M8	8	8	32	8	8	17	24	27	18	4,5
80	40	60	18	60	M20x1,5	M12	M10	8	40	8	10	22	30	32	17	/
100	50	70	25	70	M20x1,5	M12	M10	12	40	6	10	22	30	40	17	/

Bracketed values for ball screw 40x40

**Absolute stroke and length of the PNCE definition**

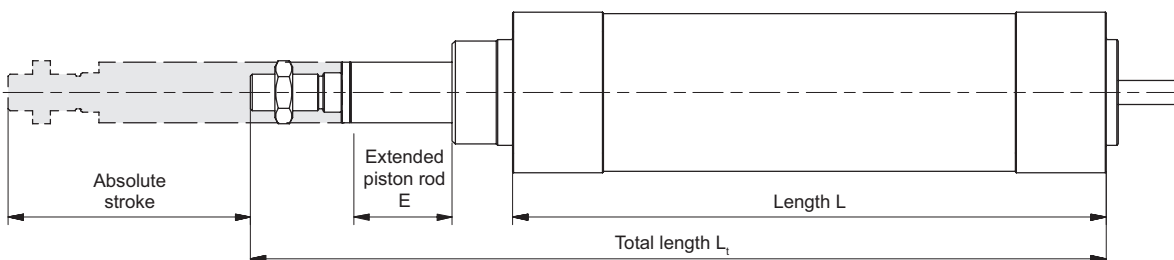

**Absolute stroke = Effective stroke + 2 × Safety stroke**  
**L = L1 + Absolute stroke**  
 $L_t = L + L2 + E$   $E_{max} = 200 \text{ mm}$

**i** The electric cylinder does not include any safety stroke

**Female thread:**  
 $L_t = L + L4 + E$   $E_{max} = 200 \text{ mm}$

**E** Extended piston rod [mm]

## ACCESSORIES

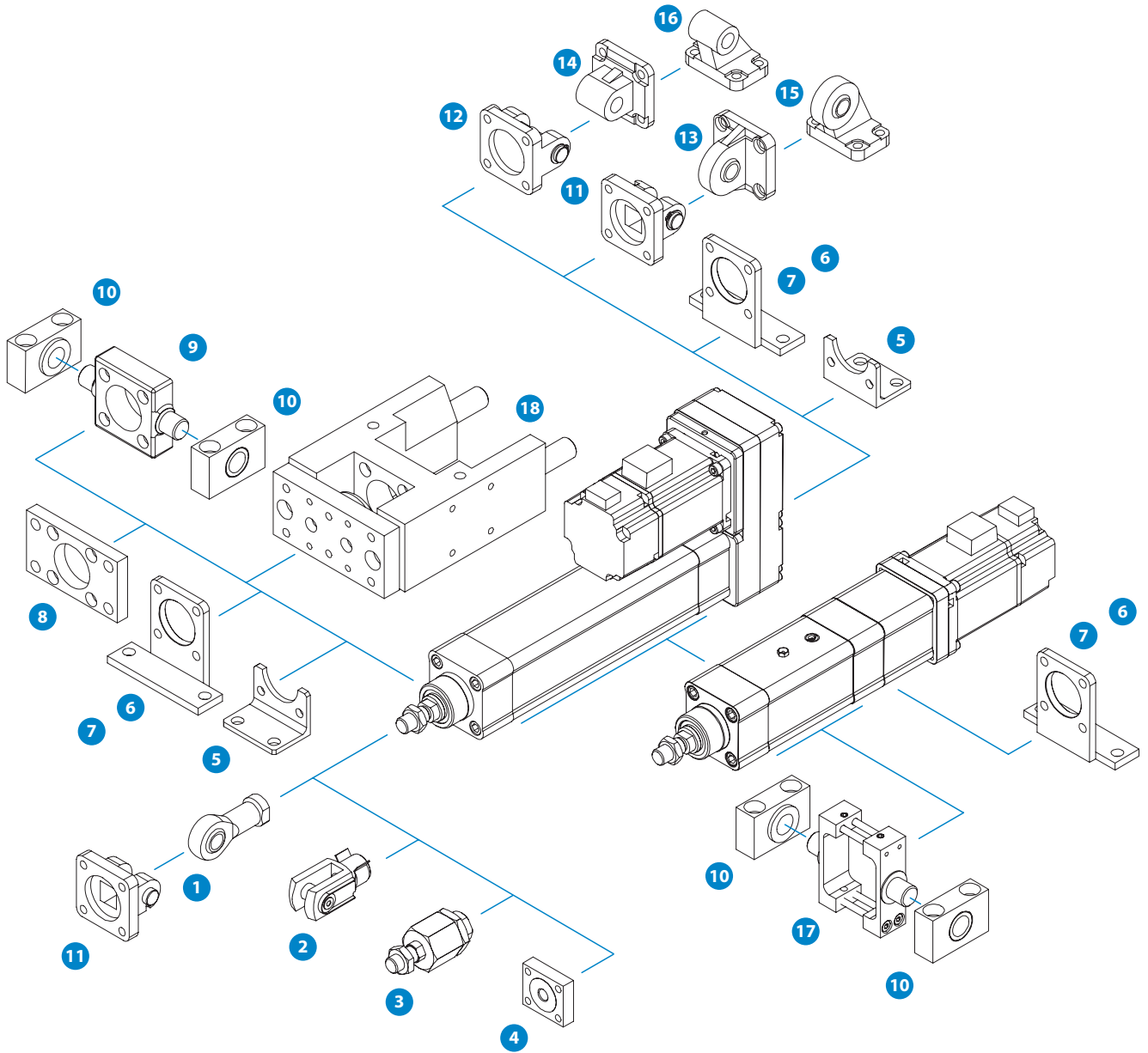

Page	19	20	21	22	23	24	25	26	27	28							
Piston rod accessories	1	2	3	4													
Mounting attachment accessories				5	6	7	8	9	10	11	12	13	14	15	16	17	
Guiding unit																18	18

**CR** This sign applies to corrosion resistant products

## Piston rod accessories

**SGS** (Material: galvanized steel, CR - stainless steel AISI 304)

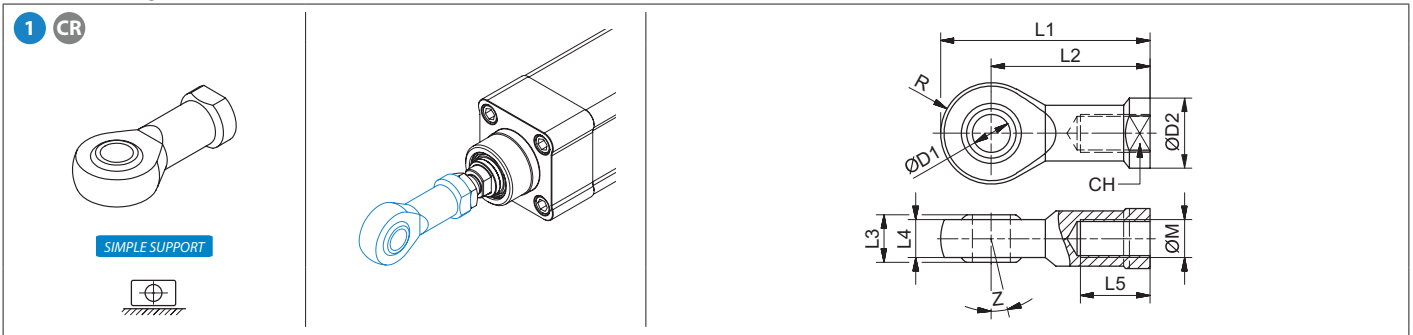

SGS			ØM	L1	L2	L3	L4	L5	ØD1 (H7)	ØD2	R	CH	Z	m	F <sub>max</sub>	
Size	Code	Code CR	[mm]											[°]	[kg]	[N]
32	9206	69550	M10x1,25	57	43	14	10,5	20	10	19	14	17	13	0,08	F <sub>PNCE</sub>	
40	9208	69551	M12x1,25	66	50	16	12	22	12	22	16	19	13	0,11	F <sub>PNCE</sub>	
50	9210	50691	M16x1,5	85	64	21	15	28	16	27	21	22	15	0,22	F <sub>PNCE</sub>	
63	9210	50691	M16x1,5	85	64	21	15	28	16	27	21	22	15	0,22	F <sub>PNCE</sub>	
80	9211	49572	M20x1,5	102	77	25	18	33	20	34	25	30	14	0,41	F <sub>PNCE</sub>	
100	9211	49572	M20x1,5	102	77	25	18	33	20	34	25	30	14	0,41	F <sub>PNCE</sub>	

**SG** (Material: galvanized steel, CR - stainless steel AISI 304)

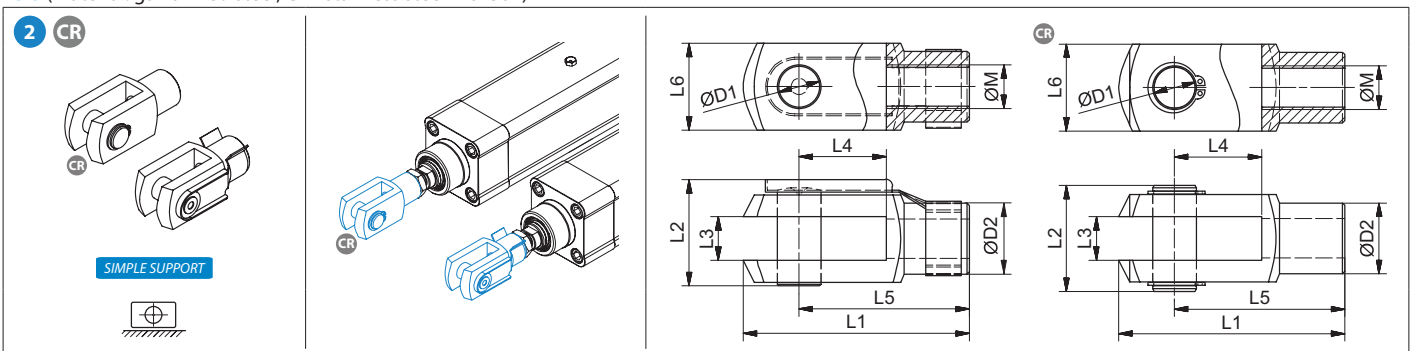

SG			ØM	L1 (±0,5)	L2	L3 (B13)	L4 (±0,5)	L5	L6	ØD1 (h11)	ØD2	m	F <sub>max</sub>	
Size	Code	Code CR	[mm]										[kg]	[N]
32	9186	69547	M10x1,25	52	26 [25]	10	20	40	20	10	18	0,09	F <sub>PNCE</sub>	
40	9189	69548	M12x1,25	62	32 [30]	12	24	48	24	12	20	0,15	F <sub>PNCE</sub>	
50	9191	69549	M16x1,5	83	40 [39]	16	32	64	32	16	26	0,33	F <sub>PNCE</sub>	
63	9191	69549	M16x1,5	83	40 [39]	16	32	64	32	16	26	0,33	F <sub>PNCE</sub>	
80	9192	70248	M20x1,5	105	48	20	40	80	40	20	34	0,68	F <sub>PNCE</sub>	
100	9192	70248	M20x1,5	105	48	20	40	80	40	20	34	0,68	F <sub>PNCE</sub>	

Bracketed values for type CR

### FK (Material: galvanized steel)

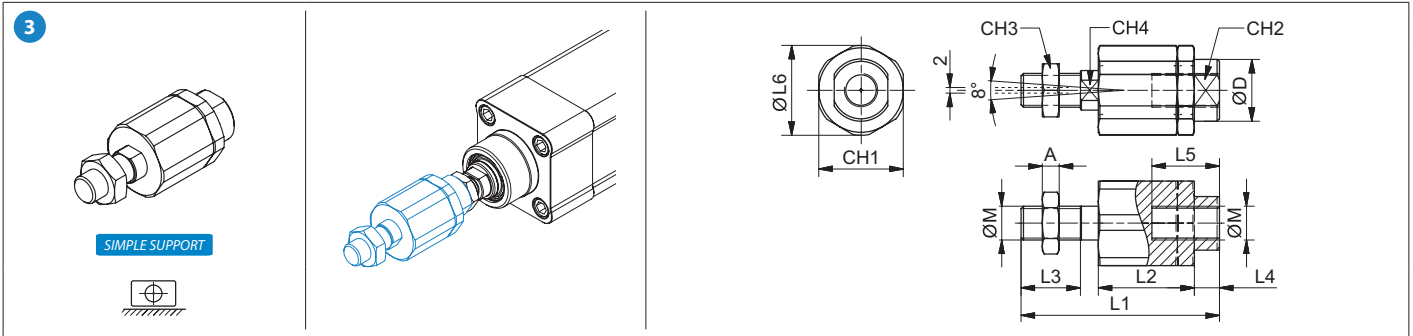

FK	ØM	L1	L2	L3	L4	L5	ØL6	A	ØD	CH1	CH2	CH3	CH4	m	F <sub>max</sub>	
Size	Code	[mm]													[kg]	[N]
32	5466	M10x1,25	71	35	20	11	23	32	6	22	30	19	17	12	0,22	F <sub>PNCE</sub>
40	5468	M12x1,25	75	35	24	11	23	32	7	22	30	19	19	12	0,23	5000
50	5470	M16x1,5	103	54	32	9	32	45	8	32	41	27	24	20	0,66	10000
63	5470	M16x1,5	103	54	32	9	32	45	8	32	41	27	24	20	0,66	10000
80	5471	M20x1,5	119	54	40	17	39	45	9	32	41	27	30	20	0,70	10000
100	5471	M20x1,5	119	54	40	17	39	45	9	32	41	27	30	20	0,70	10000

### KSZ (Material: galvanized steel)

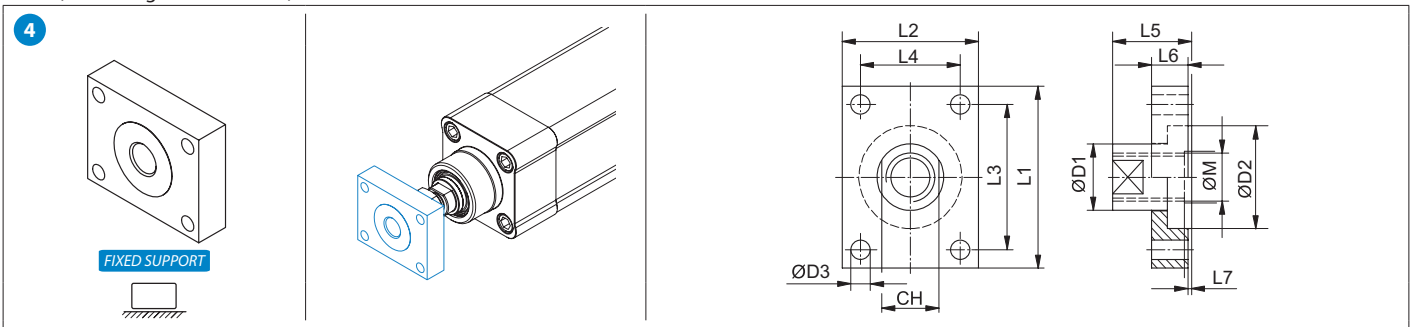

KSZ	ØM	L1	L2	L3	L4	L5	L6	L7	ØD1 (-0,2)	ØD2	ØD3 (H13)	CH	m	F <sub>max</sub>	
Size	Code	[mm]											[kg]	[N]	
32	5229	M10x1,25	40	35	30	25	20	10	0,1	17	26	5,5	15	0,11	F <sub>PNCE</sub>
40	5230	M12x1,25	50	40	40	30	22	12	0,1	17	26	5,5	15	0,18	F <sub>PNCE</sub>
50	5231	M16x1,5	60	45	48	33	25	12	0,1	22	34	6,6	19	0,25	F <sub>PNCE</sub>
63	5231	M16x1,5	60	45	48	33	25	12	0,1	22	34	6,6	19	0,25	F <sub>PNCE</sub>
80	5232	M20x1,5	72	50	57	35	32	15	0,1	30	44	9	27	0,42	24800
100	5232	M20x1,5	72	50	57	35	32	15	0,1	30	44	9	27	0,42	24800

## Mounting attachments' accessories

**HG** (Material: galvanized steel, CR - stainless steel AISI 304)

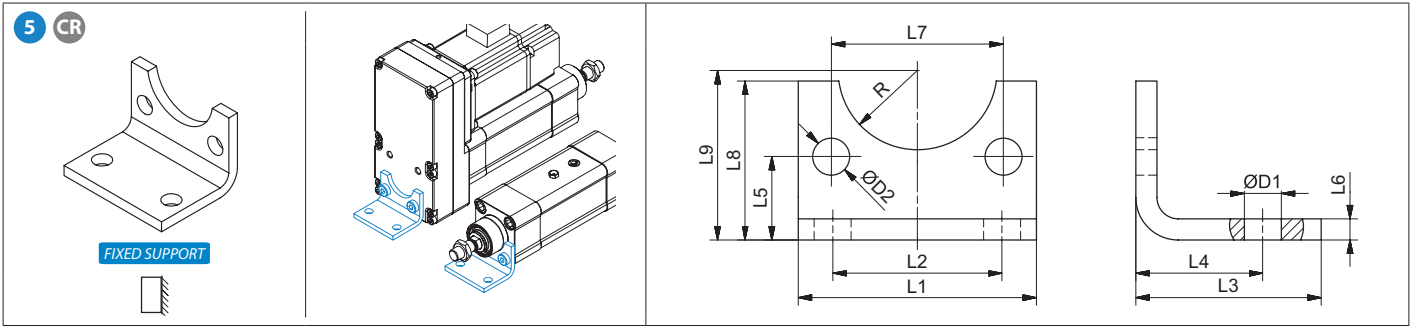

HG					L1	L2	L3	L4	L5	L6	L7	L8	L9	ØD1	ØD2	R	m	F <sub>max</sub>	
Size	Code <sup>1</sup>	Code CR <sup>1</sup>	Code MSD <sup>2</sup>	Code MSD CR <sup>2</sup>	[mm]													[kg]	[N]
32	69601	69605	69597	69609	45	32	35	24	15,75	4	32,5	30	32	7	7	15	0,09	F <sub>PNCE</sub>	
40	69602	69606	69598	69610	52	36	36	28	17	4	38	30	36	10	7	17,5	0,10	3500	
50	69603	69607	69599	69611	65	45	47	32	21,75	5	46,5	36	45	10	9	20	0,20	5400	
63	69604	69608	69600	69612	75	50	45	32	21,75	5	56,5	35	50	10	9	22,5	0,22	6200	

**HGL** (Material: galvanized steel)

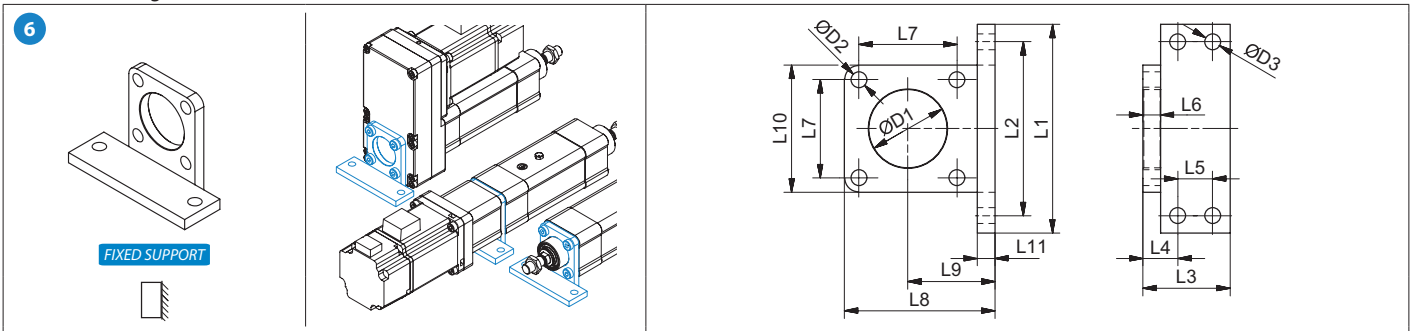

HGL			L1	L2	L3	L4	L5	L6	L7	L8	L9	L10	L11	ØD1	ØD2	ØD3	m	F <sub>max</sub>
Size	Code <sup>1,3</sup>	Code MSD <sup>2</sup>	[mm]													[kg]	[N]	
32	69162	69613	79	65	30	16	-	6	32,5	55,5	32	47	6	30	7	7	0,20	F <sub>PNCE</sub>
40	69163	69614	90	75	30	16	-	6	38	63,0	36	54	6	35	7	9	0,24	5100
50	69164	69615	110	90	35	19	-	10	46,5	77,5	45	65	10	40	9	9	0,56	11100
63	69165	69616	120	100	50	20	20	10	56,5	87,5	50	75	10	45	9	9	0,81	11100

<sup>1</sup> Front cap mounting

<sup>2</sup> Motor side drive mounting

<sup>3</sup> Motor adapter mounting

### HGLL (Material: galvanized steel)

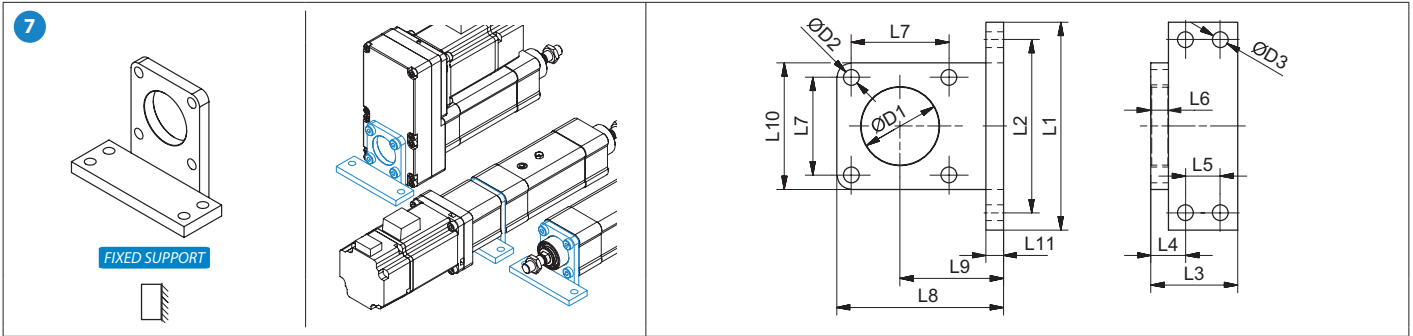

HGLL			L1	L2	L3	L4	L5	L6 (±0,5)	L7	L8	L9 (±0,1)	L10	L11 (±0,5)	ØD1 (H11)	ØD2 (H13)	ØD3 (H13)	m	F <sub>max</sub>
Size	Code <sup>1,3</sup>	Code MSD <sup>2</sup>	[mm]														[kg]	[N]
32	69429	69617	79	65	30	16	-	6	32,5	58,5	35	47	6	30	7	7	0,21	F <sub>PNCE</sub>
40	69166	69618	90	75	30	16	-	6	38	72,0	45	54	6	35	7	9	0,26	2800
50	69167	69619	110	90	35	19	-	10	46,5	92,5	60	65	10	40	9	9	0,64	7100
63	69168	69620	120	100	50	20	20	10	56,5	97,5	60	75	10	45	9	9	0,87	10100
80	77284		153	128	62	27	25	12	72,0	128,5	82	93	13	60	11	11	1,71	13200
100	78955		178	148	72	27	30	15	89	137,0	82	110	15	70	11	11	2,57	F <sub>PNCE</sub>

<sup>1</sup> Front cap mounting

<sup>2</sup> Motor side drive mounting

<sup>3</sup> Motor adapter mounting

### FG (Material: galvanized steel, CR - stainless steel AISI 304)

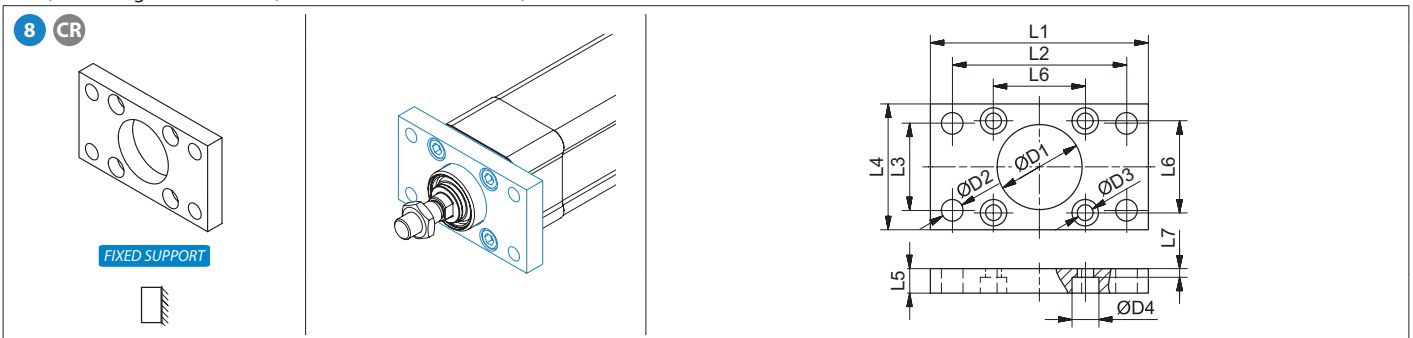

FG			L1	L2	L3	L4	L5	L6	L7	ØD1 (H11)	ØD2 (H13)	ØD3	ØD4	m	F <sub>max</sub>
Size	Code	Code CR	[mm]											[kg]	[N]
32	5485	69495	80	64	32	45	10	32,5	5	30	7	6,5	10,5	0,22	F <sub>PNCE</sub>
40	5487	69497	90	72	36	52	10	38	5	35	9	6,5	10,5	0,28	F <sub>PNCE</sub>
50	5489	69498	110	90	45	65	12	46,5	6,5	40	9	8,5	13,5	0,53	F <sub>PNCE</sub>
63	5491	69499	120	100	50	75	12	56,5	6,5	45	9	8,5	13,5	0,68	F <sub>PNCE</sub>
80	83009	83013	150	126	63	95	16	72	9	60	12	10,5	16,5	1,40	F <sub>PNCE</sub>
100	83010	83014	170	150	75	115	16	89	9	70	14	10,5	16,5	1,92	F <sub>PNCE</sub>



**ZK** (Material: galvanized steel)

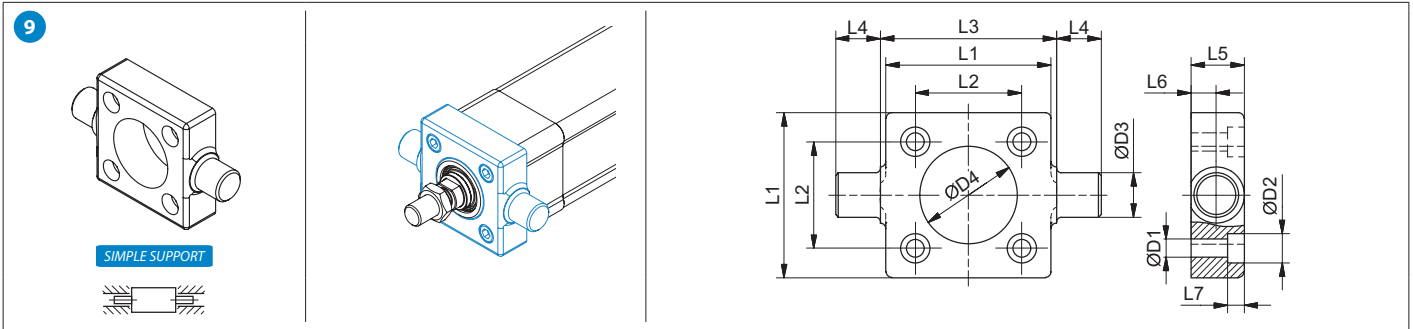

ZK		L1	L2	L3 (h14)	L4 (h14)	L5	L6 (+0,2 / 0)	L7 (+0,5 / 0)	ØD1	ØD2	ØD3 (e9)	ØD4 (H11)	m	F <sub>max</sub>
Size	Code	[mm]											[kg]	[N]
32	69075	46	32,5	50	12	14	6,5	6	6,5	10,5	12	30	0,17	F <sub>PNCE</sub>
40	69083	59	38	63	16	19	9	6	6,5	10,5	16	35	0,43	F <sub>PNCE</sub>
50	69084	69	46,5	75	16	19	9	8	8,5	13,5	16	40	0,58	F <sub>PNCE</sub>
63	69085	84	56,5	90	20	24	11,5	8	8,5	13,5	20	45	1,12	F <sub>PNCE</sub>
80	83027	102	72	110	20	24	11,5	10	10,5	16,5	20	60	1,57	F <sub>PNCE</sub>
100	83028	125	89	132	25	29	14	10	10,5	16,5	25	70	2,93	F <sub>PNCE</sub>

**LZ** (Material: galvanized steel)

**i** Set contains 2 pcs

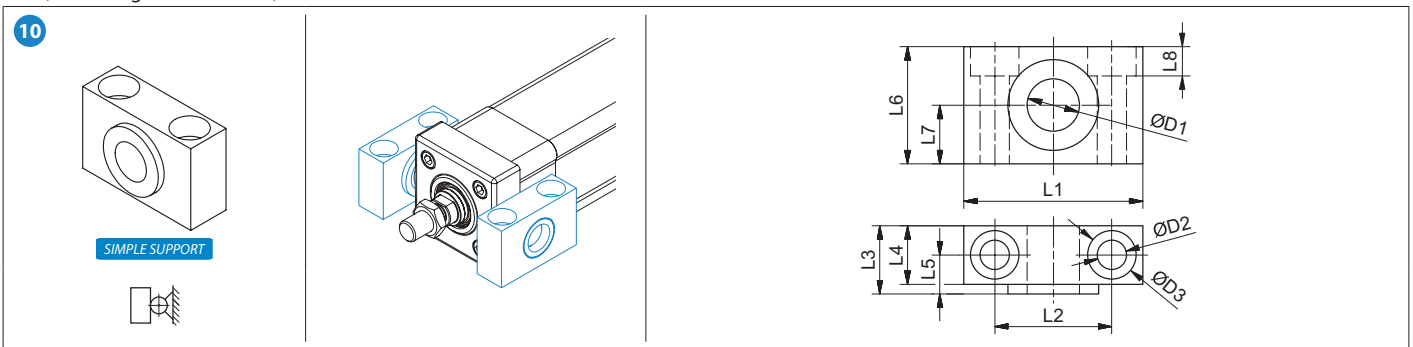

LZ		L1	L2 (±0,2)	L3	L4	L5	L6	L7 (±0,1)	L8 (±0,5)	ØD1 (F7)	ØD2 (H13)	ØD3 (H13)	m	F <sub>max</sub>
Size	Code	[mm]											[kg]	[N]
32	8139	46	32	18	15	10,5	30	15	7	12	6,6	11	0,10	F <sub>PNCE</sub>
40	8141	55	36	21	18	12	36	18	9	16	9	15	0,15	F <sub>PNCE</sub>
50	8141	55	36	21	18	12	36	18	9	16	9	15	0,15	9200
63	8143	65	42	23	20	13	40	20	11	20	11	18	0,25	12800
80	8143	65	42	23	20	13	40	20	11	20	11	18	0,25	12800
100	8135	75	50	28,5	25	16	50	25	13	25	14	20	0,40	20000

### SGN (Material: aluminium, CR - stainless steel AISI 316)

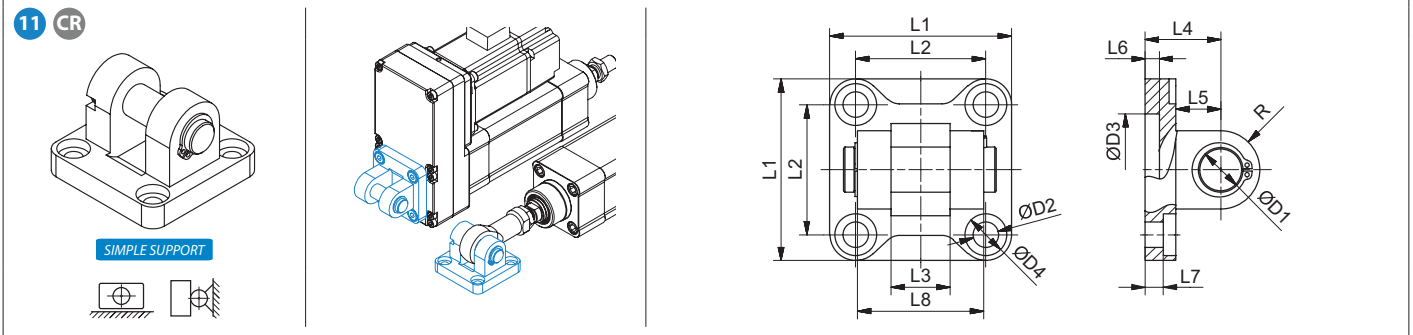

SGN					L1 (±0,5)	L2	L3	L4 (±0,2)	L5	L6	L7	L8	ØD1 (f7)	ØD2 (H13)	ØD3 (H11)	ØD4 (H13)	R	m	F <sub>max</sub>
Size	Code <sup>1</sup>	Code CR <sup>1</sup>	Code MSD <sup>2</sup>	Code MSD CR <sup>2</sup>	[mm]													[kg]	[N]
32	9200	69538	69621	69625	45	32,5	14	22	13 [12]	5	5,5	34	10	6,6	30	11	10	0,10 [0,20]	F <sub>PNCE</sub>
40	9201	69539	69622	69626	52 [55]	38	16	25	16 [15]	5	5,5	40	12	6,6	35	11	12	0,14 [0,30]	5700
50	9202	69540	69623	69627	65	46,5	21	27	16 [17]	5	6,5	45	16	9	40	15	12	0,26 [0,48]	7600
63	9203	69541	69624	69628	75	56,5	21	32	21 [20]	5	6,5	51	16	9	45	15	16	0,35 [0,70]	9600
80	9204	83257	9204	83257	95	72	25	36	22	5	10	65	20	11	45	18	20	0,68 [1,49]	16000
100	9198	83259	9198	83259	115	89	25	41	27 [25]	5	10	75	20	11	55	18	22	0,93 [2,16]	20000

Bracketed values for type CR

### SBG (Material: aluminium, CR - stainless steel AISI 304)

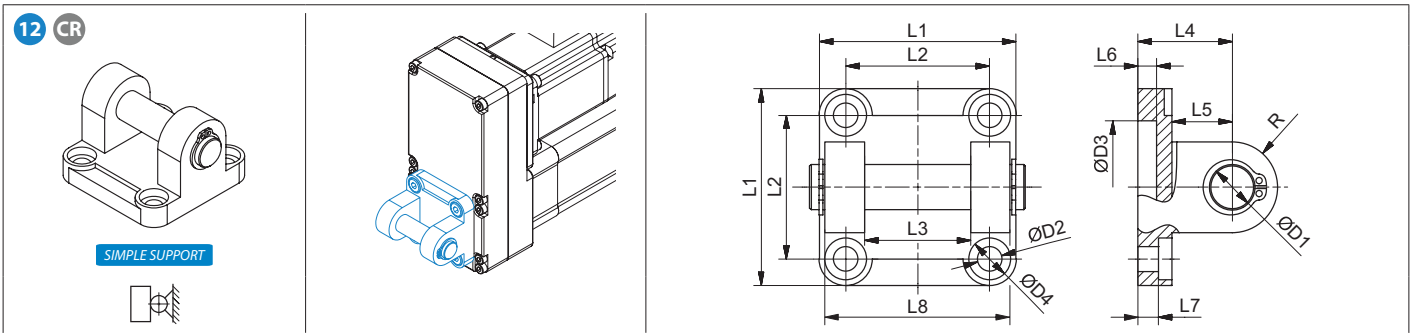

SBG			L1	L2	L3	L4 (±0,2)	L5	L6	L7	L8	ØD1 (e8)	ØD2 (H13)	ØD3 (H11)	ØD4 (H13)	R	m	F <sub>max</sub>
Size	Code MSD <sup>2</sup>	Code MSD CR <sup>2</sup>	[mm]													[kg]	[N]
32	69629	69633	45	32,5	26	22	13	5	5,5	45	10	6,6	30	11	10	0,11 [0,20]	F <sub>PNCE</sub>
40	69630	69634	52	38	28	25	16	5	5,5	52	12	6,6	35	11	12	0,18 [0,31]	F <sub>PNCE</sub>
50	69631	69635	65	46,5	32	27	16	5	6,5	60	12	9	40	15	12	0,23 [0,45]	8000
63	69632	69636	75	56,5	40	32	21	5	6,5	70	16	9	45	15	16	0,36 [0,70]	11000
80	9252	83251	93	72	50	36	22	5	10	90	16	11	45	18	16	0,61 [1,42]	15360
100	9244	83253	110	89	60	41	27	5	10	110	20	11	55	18	20	0,98 [2,50]	24000

Bracketed values for type CR

<sup>1</sup> Front cap mounting

<sup>2</sup> Motor side drive mounting

**SSG** (Material: aluminium, CR - stainless steel AISI 316)

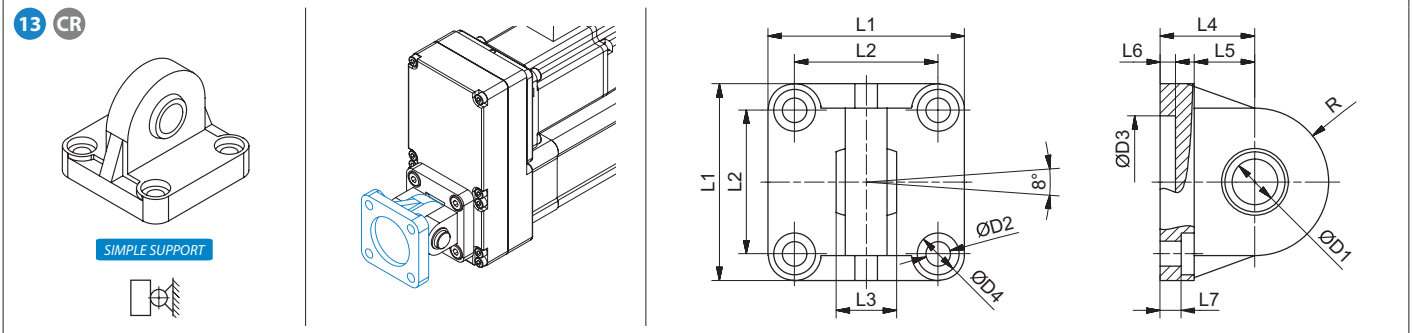

SSG			L1	L2	L3	L4 (JS 15)	L5	L6	L7 (±0,5)	ØD1 (H7)	ØD2 (H13)	ØD3 (H11)	ØD4 (H13)	R	m	F <sub>max</sub>
Size	Code	Code CR	[mm]												[kg]	[N]
32	9292	69542	45	32,5	14	22	12	5	5,5	10	6,6	30	11	16 [15]	0,09 [0,18]	F <sub>PNCE</sub>
40	9294	69544	52 [55]	38	16	25	15	5	5,5	12	6,6	35	11	18	0,13 [0,29]	F <sub>PNCE</sub>
50	9296	50709	65	46,5	21	27	15 [17]	5	6,5	16	9	40	15	21	0,24 [0,42]	14400
63	9298	69546	75	56,5	21	32	20	5	6,5	16	9	45	15	23	0,30 [0,66]	14400
80	9300	83249	95	72	25	36	20 [22]	9 [5]	10	20	11	45	18	28 [27]	0,54 [1,24]	22500
100	19731	83250	115	89	25	41	25	9 [5]	10	20	11	55	18	30	0,68 [1,90]	22500

Bracketed values for type CR

**SGL** (Material: aluminium, CR - stainless steel AISI 304)

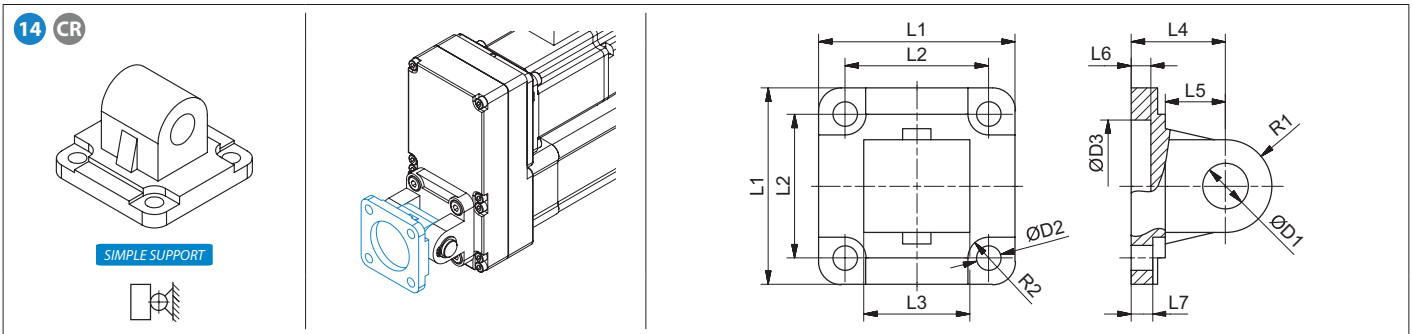

SGL			L1	L2	L3	L4 (±0,2)	L5	L6	L7	ØD1 (H9)	ØD2 (H13)	ØD3 (H11)	R1	R2	m	F <sub>max</sub>
Size	Code	Code CR	[mm]												[kg]	[N]
32	9176	69500	45	32,5	26	22	13	5	5,5	10	6,6	30	10	5,5	0,08 [0,21]	F <sub>PNCE</sub>
40	9178	69501	52	38	28	25	16	5	5,5	12	6,6	35	12	5,5	0,11 [0,30]	F <sub>PNCE</sub>
50	9180	69502	65	46,5	32	27	16	5	6,5	12	9	40	12	7,5	0,18 [0,43]	9200
63	9182	69503	75	56,5	40	32	21	5	6,5	16	9	45	16	7,5	0,27 [0,74]	14300
80	9184	83091	93	72	50	36	22	5	10	16	11	45	16	9	0,47 [1,31]	19200
100	9168	83092	110	89	60	41	27	5	10	20	11	55	20	9	0,79 [2,21]	27100

Bracketed values for type CR

### LSG (Material: steel (black cathaphoresis), CR - stainless steel AISI 316)

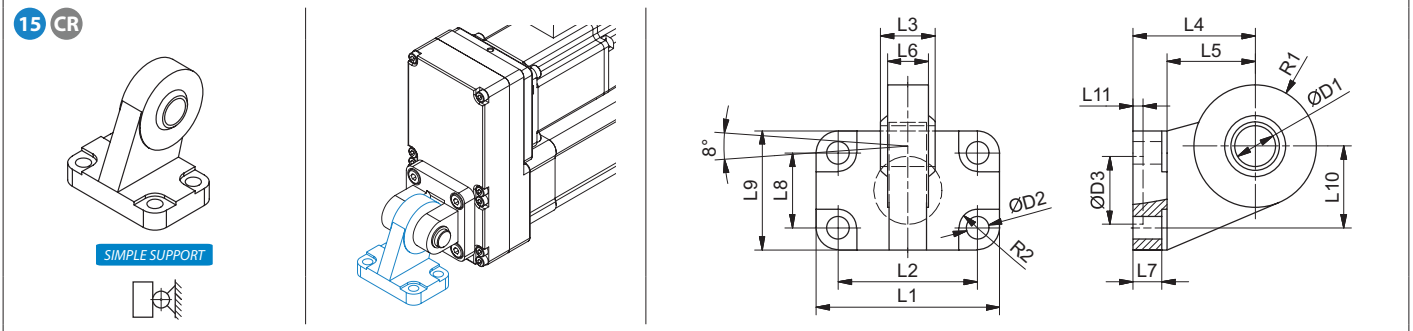

LSG			L1	L2	L3	L4 (JS 15)	L5	L6	L7	L8	L9	L10 (JS 15)	L11	ØD1 (H7)	ØD2 (H13)	ØD3 (H13)	R1	R2 (H13)	m	F <sub>max</sub>	
Size	Code	Code CR	[mm]																	[kg]	[N]
32	8129	69071	51	38	14	32	22	10,5	8,5	18	31	21	3	10	6,6	20	15	5,5	0,18	F <sub>PNCE</sub>	
40	8130	69072	54	41	16	36	26	12	8,5	22	35	24	3	12	6,6	20	18	5,5	0,27	F <sub>PNCE</sub>	
50	8131	69073	65	50	21	45	33	15	10,5	30	45	33	3	16	9	20	20	7,5	0,46	F <sub>PNCE</sub>	
63	8132	69069	67	52	21	50	38	15	10,5	35	50	37	3	16	9	20	23	7,5	0,55	F <sub>PNCE</sub>	
80	8133	83089	86	66	25	63	49	18	11,5	40	60	47	3	20	11	20	27	9	0,97	F <sub>PNCE</sub>	
100	8127	83090	96	76	25	71	56	18	12,5	50	70	55	3	20	11	20	30	9	1,33	F <sub>PNCE</sub>	

### LG (Material: aluminium, CR - stainless steel AISI 304)

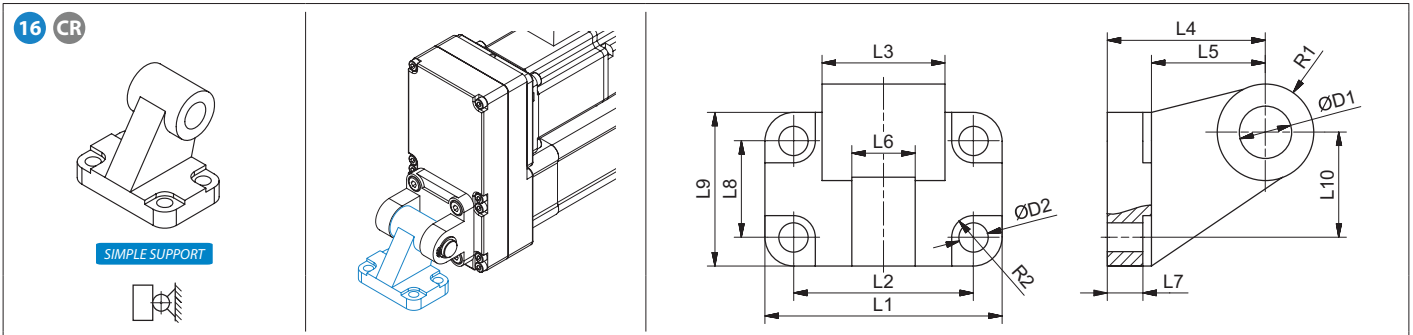

LG			L1	L2	L3	L4	L5	L6	L7	L8	L9	L10	ØD1 (H9)	ØD2 (H13)	R1	R2	m	F <sub>max</sub>			
Size	Code	Code CR	[mm]																	[kg]	[N]
32	8119	69505	51	38	26	32	24	10	6,4	18	31	21	10	6,6	10	5,5	0,06 [0,16]	F <sub>PNCE</sub>			
40	8120	69506	54	41	28	36	26	15	8,4	22	35	24	12	6,6	11	5,5	0,14 [0,24]	F <sub>PNCE</sub>			
50	8121	69507	65	50	32	45	33	16	10,4	30	45	33	12	9	13	7,5	0,14 [0,42]	9200			
63	8122	69508	67	52	40	50	36	16	12,4	35	50	37	16	9	15	7,5	0,20 [0,53]	15300			
80	8123	83087	86	66	50	63	49	20	11,5	40	60	47	16	11	15	9	0,39 [0,98]	19200			
100	8117	83088	96	76	60	71	54	20	14,5	50	70	55	20	11	19	9	0,55 [1,48]	F <sub>PNCE</sub>			

Bracketed values for type CR

**ZKCE** (Material: galvanized steel)

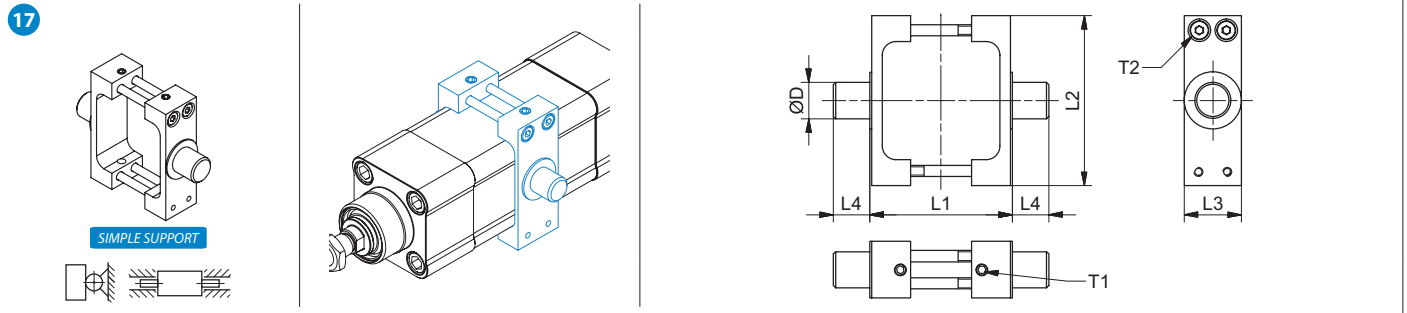

ZKCE		L1	L2	L3	L4	ØD	T1	T2	m	F <sub>max</sub>
Size	Code	[mm]					[Nm]		[kg]	[N]
32	69148	50	65	25	12	12	5	3	0,15	F <sub>PNCE</sub>
40	69149	63	75	25	16	16	7	5	0,30	F <sub>PNCE</sub>
50	69150	75	95	30	16	16	7	5	0,52	8500
63	69151	90	105	30	20	20	7	5	0,64	8500
80	100349	110	130	30	20	20	11	9	0,89	10000
100	100350	132	145	40	24,5	25	25	19	1,52	16000

**Guiding unit**

**GUH** (Material: body - aluminium, guides - steel)

**i** PERMISSIBLE LOAD

**BA** With slide bushes  
Displacement force = 15 N\*

**BB** With ball bushes  
Displacement force = 15 N\*

\* For the case of GUH 80/100 displacement force = 40 N

### HOW TO ORDER



**Guiding unit**

**Size:**

• 32 • 40 • 50 • 63 • 80 • 100

**Absolute stroke + Extended piston rod E [mm]**

**Option:** • BA: with slide bushes  
• BB: with ball bushes

**i** Absolute stroke + extended piston rod E = max. 500mm

**i** For guiding unit stroke over 500 mm please contact us

PNCE	Mass of GUH	Moved mass of GUH*
	$m_{GUH}$ [kg]	$M_{m, GUH}$ [kg]
32	$1,57 + 0,0017 \times (\text{Abs. stroke} + E)$	$0,86 + 0,0017 \times (\text{Abs. stroke} + E)$
40	$2,48 + 0,0031 \times (\text{Abs. stroke} + E)$	$1,32 + 0,0031 \times (\text{Abs. stroke} + E)$
50	$4,18 + 0,0047 \times (\text{Abs. stroke} + E)$	$2,47 + 0,0047 \times (\text{Abs. stroke} + E)$
63	$5,54 + 0,0047 \times (\text{Abs. stroke} + E)$	$2,90 + 0,0047 \times (\text{Abs. stroke} + E)$
80	$10,72 + 0,0070 \times (\text{Abs. stroke} + E)$	$5,66 + 0,0070 \times (\text{Abs. stroke} + E)$
100	$13,42 + 0,0070 \times (\text{Abs. stroke} + E)$	$6,42 + 0,0070 \times (\text{Abs. stroke} + E)$

\* The moved mass of GUH is already considered in the equation for calculating the mass of GUH  $m_{GUH}$

E	Extended piston rod [mm]															
PNCE	L1	L2	L3	L4	L5	L6	L7	L8	L9	L10	L11	L12	L13	L14	L15	L16
Size	[mm]															
32	177	37	61	125	64	32,5	32,5	12	6,5	32,5	78	90	97	32,5	45	49
40	192	37	69	139	74	38	38	15	6,5	38	84	110	115	38	54	58
50	205	38	85	148	89	46,5	46,5	15	8,5	46,5	100	130	137	46,5	63	69
63	237	38	100	182	88	56,5	56,5	15	8,5	56,5	105	145	152	56,5	79	85
80	280	42	130	215	110	72	72	20	10,5	72	130	180	189	72	99	105
100	280	37	130	220	115	89	89	20	10,5	89	150	200	213	89	120	129

t	L17	L18	L19	L20	L21	L22	ØD1	ØD2	ØD3	ØD4	ØD5 × l (H7)	ØM1	ØM2	ØM3	CH	
Size	[mm]															
32	4,3	76	17	74	31	18	12	30	6,5	10,5	6×6	M6×12	M6	M10×1,25	15	
40	11	81	21	87	36	21	16	35	6,5	10,5	6×10	M6×12	M6	M12×1,25	15	
50	18,5	78	26	104	45	24	20	40	8,5	13,5	6×10	M8×16	M8	M16×1,5	22	
63	15,3	111	26	119	45	24	20	45	8,5	13,5	6×10	M8×16	M8	M16×1,5	22	
80	21	128	34	148	56	31	25	60	11	17	6×10	M10×18	M10	M20×1,5	27	
100	24,5	128	39	172	56	31	25	70	11	17	6×10	M10×18	M10	M20×1,5	27	

**Blanking screws** (Material: stainless steel AISI 304)

**i** Set contains 4 pcs

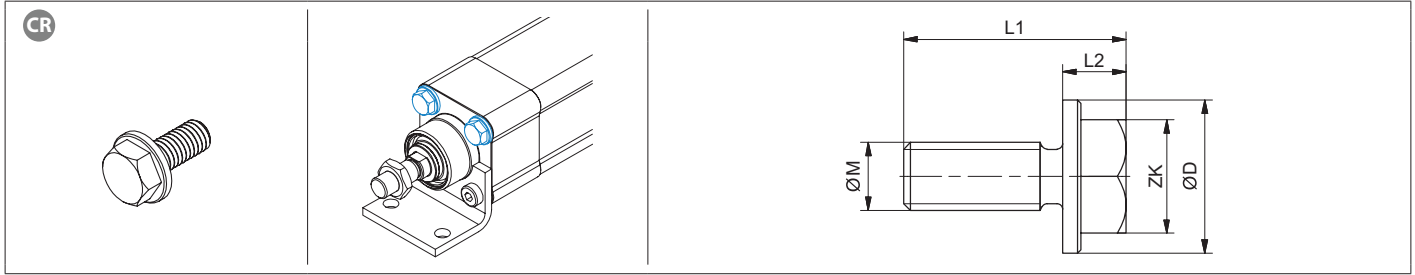

Blanking screw		ØM	L1	L2	ØD	ZK
Tip / Type	Code	[mm]				
<b>M6</b>	<b>69156</b>	M6	19,5	5,5	12,8	10
<b>M8</b>	<b>69157</b>	M8	24	8	17	13
<b>M10</b>	<b>82901</b>	M10	24,5	8,5	19,3	15

**LUBRICATION POSITION**

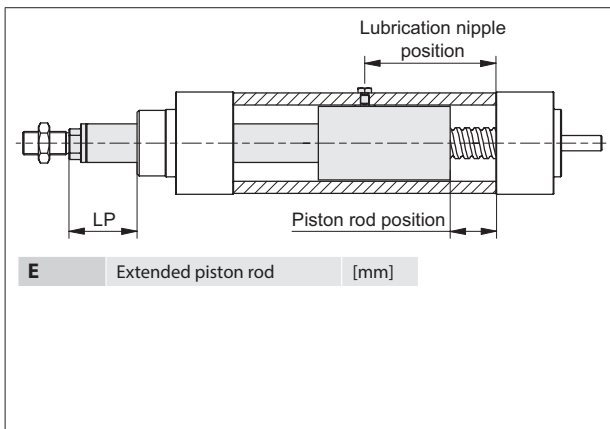

PNCE	Ball screw d×l [mm]	Lubrication nipple position (±0,2) [mm]	Piston rod position (±0,5) [mm]	LP (±0,5) [mm]
<b>32</b>	12×5, 12×0	Abs. stroke / 2 + 38,0	Abs. stroke / 2 - 9,0	Abs. stroke / 2 + E - 1,0
<b>40</b>	16×5, 16×10, 16×16	Abs. stroke / 2 + 42,0	Abs. stroke / 2 - 10,5	Abs. stroke / 2 + E - 0,5
<b>50</b>	20×5, 20×10, 20×20	Abs. stroke / 2 + 53,5	Abs. stroke / 2 - 22,0	Abs. stroke / 2 + E - 10,0
	20×50		Abs. stroke / 2 - 5,0	Abs. stroke / 2 + E + 7,0
<b>63</b>	25×5, 25×10	Abs. stroke / 2 + 47,5	Abs. stroke / 2 - 13,5	Abs. stroke / 2 + E - 1,5
	25×25		Abs. stroke / 2 - 4,0	Abs. stroke / 2 + E + 8,0
<b>80</b>	32×5, 32×10, 32×20, 32×32	Abs. stroke / 2 + 62,0	Abs. stroke / 2 - 27,0	Abs. stroke / 2 + E - 12,0
<b>100</b>	40×5, 40×10, 40×20	Abs. stroke / 2 + 70,0	Abs. stroke / 2 - 20,0	Abs. stroke / 2 + E - 3,0
	40×40		Abs. stroke / 2 + 77,5	Abs. stroke / 2 - 27,5

The lubrication nipple on the aluminum profile of the electric cylinder allows easy re-lubrication of the ball screw. To achieve the lubricating position the piston rod must be moved from the end position into position (Piston rod position) shown in the table above. The same position is achieved when the distance LP is obtained.

**MOTOR ADAPTER**

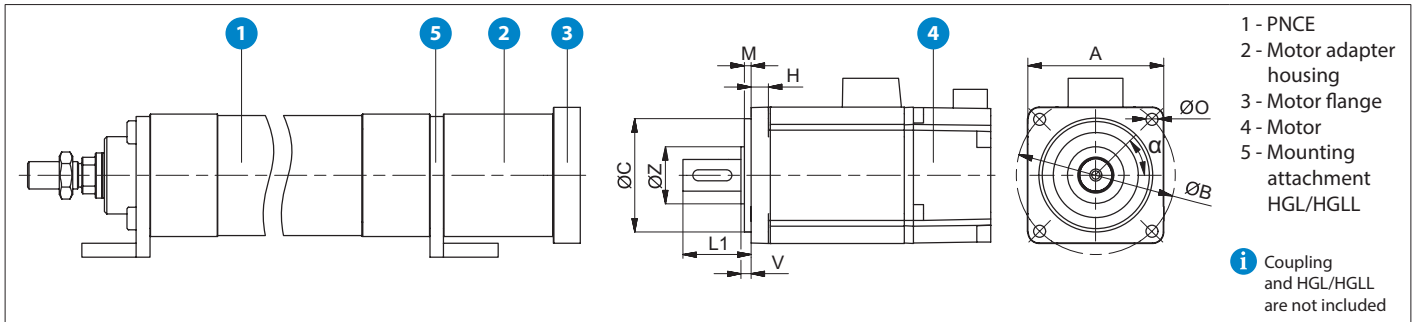

**HOW TO ORDER**

VK - PNCE40 - EKL10 - 1 - S - 60 - 70 - 50 - 3 - 30 - 7,5 - 5,5 - 4,6 - 29 - 45

Motor adapter  
PNCE series  
Coupling type  
According to the customer's specification (page 32)  
Mounting attachment HGL/HGLL:  
• 0: without  
• 1: with

Motor dimensions [mm]  
A, ØB, ØC, M, L1, H, ØO, V, ØZ, α [°]

**Versions:**  
• S: Standard  
• IP65CR: IP65CR protection (IP65CR version is also suitable for some applications in the food industry. More information on request.)

## MOTOR SIDE DRIVE WITH A TIMING BELT

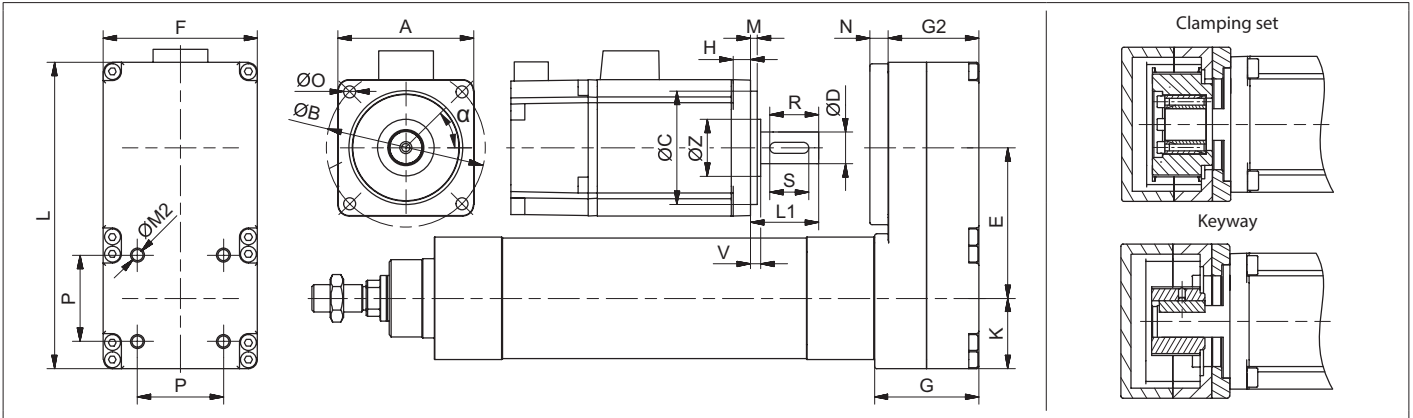

### HOW TO ORDER

MSD - PNCE40 - T1 - 1 - S - 60 - 70 - 50 - 3 - 30 - 14 - 7,5 - 5,5 - 20 - 20 - 4,6 - 29 - 45

Motor side drive  
PNCE series  
Type

Gear ratio  
Versions:  
• S: Standard  
• IP65CR: IP65CR protection

Motor dimensions [mm]

α [°]

### Technical data

PNCE	Type	Gear ratio i	Max. drive torque M <sub>p,MSD</sub> [Nm]	Maximum radial load on shaft* F <sub>r,MSD</sub> [N]	No load torque M <sub>0,MSD</sub> [Nm]	Mass moment of inertia J <sub>MSD</sub> [10 <sup>-6</sup> kg m <sup>2</sup> ]	Mass*** m <sub>MSD</sub> [kg]	Motor size limits [mm]									
								A		ØB		L1		ØC		ØD	
								max	max	min	max	max	max	Clamping set max	Keyway min	Keyway max	
32	T0	1	1	40	0,02	5,4	0,5	50	60	-	26	32	10	-	-		
		1	1,4	40	0,10	53	0,85	74	80	25	38	50	16	-	-		
	T1	1,5	0,9	40	0,07	31	0,72	74	80	25	38	50	10	>10	14		
40	T1	1	3	80	0,10	62	0,92	74	80	25	42	50	16	-	-		
		1,5	2	80	0,07	44	0,79	74	80	25	42	50	10	>10	14		
	T2	1	4	80	0,27	288	1,66	95	110	30	52	75	28	-	-		
		1,5	2,6	80	0,18	200	1,39	95	110	30	52	75	16	>16	24		
50	T1	1	9	170	0,27	363	1,76	95	110	30	52	75	28	-	-		
		1,5	6	170	0,18	245	1,48	95	110	30	52	75	16	>16	24		
	T2	1	9	205	0,30	928	3,63	122	140	35	62	100	35	-	-		
		2	4,5	205	0,15	559	3,06	122	140	35	62	95	15	>15	22		
63	T1	1	21	500	0,34	1041	3,72	122	140	35	62	100	35	-	-		
		2	8,9	400	0,17	616	3,10	122	140	35	62	95	15	>15	22		
80	T1	1	24	500	0,34	1008	3,72	122	140	35	68	100	35	-	-		
		2	10	400	0,17	575	3,30	122	140	35	68	95	15	>15	22		
	T2	1	48	500	0,37	6000	9,30	160	195	45	99	145	40	-	-		
		2	24	500	0,18	4145	8,60	160	195	45	99	130	28	>28	38		
100	T1	1	110	1000	0,4	6181	9,40	160	195	45	99	145	40	-	-		
		2	50	1000	0,2	4333	8,80	160	195	45	99	130	28	>28	38		

\* This is the load which is linearly dependent on the maximum drive torque M<sub>p,MSD</sub> and is generated by the correct pretension of the belt. This load needs to be reduced in accordance with the capabilities of the motor.

\*\* Minimum dimension L1 depends on the size of particular clamping set. Values can be found on the bottom table on page 31.

\*\*\* This is an average value. It could differ depending to the motor dimensions.



## Dimensions

PNCE	Type	Gear ratio i	E (±0,5)	F	G	G2	N *	K	L	P	ØM2
32	T0	1	78	50	39	33	6	23,5	128	32,5	M6x8,5
	T1	1	65	68	42	36	8	31	135	32,5	M6x8,5
1,5		64,5									
40	T1	1	65	68	46	40	8	31	135	38	M6x8,5
		1,5	64,5								
	T2	1	82,5	89	57	51	8	42	174	38	M6x8,5
		1,5	81,7								
50	T1	1	82,5	89	57	51	8	42	174	46,5	M8x9
		1,5	81,7								
	T2	1	120	116	66	60	10	49,5	239	46,5	M8x9
		2	125,8								
63	T1	1	120	116	66	60	10	49,5	239	56,5	M8x10
		2	125,8								
80	T1	1	120	116	77	67	10	49,5	239	72	M10x17
		2	125,8								
	T2	1	155	160	102	94	15	77	317	72	M10x17
		2	151,6								
100	T1	1	155	160	102	94	15	77	317	89	M10x17
		2	151,6								

\* This is a standard value. It could differ depending to the motor dimensions M and L1

## Minimum dimension L1 [mm] depends on the motor shafts diameter ØD

PNCE	Type	Gear ratio i	ØD [mm]																											
			6	6,35	7	8	9	9,53	10	11	12	14	15	16	17	18	19	20	22	24	25	25,4	28	30	32	35	38	40		
32	T0	1	18	18	18	18	20	20	20	-	-	-	-	-	-	-	-	-	-	-	-	-	-	-	-	-	-	-		
	T1	1	18	18	18	18	20	20	20	23	23	27	27	27	-	-	-	-	-	-	-	-	-	-	-	-	-	-		
		1,5	18	18	18	18	20	20	20	-	-	-	-	-	-	-	-	-	-	-	-	-	-	-	-	-	-	-		
40	T1	1	18	18	18	18	20	20	20	23	23	27	27	27	-	-	-	-	-	-	-	-	-	-	-	-	-	-		
		1,5	18	18	18	18	20	20	20	-	-	-	-	-	-	-	-	-	-	-	-	-	-	-	-	-	-	-		
	T2	1	18	18	18	18	20	20	20	23	23	27	27	27	31	31	31	31	31	36	36	36	36	-	-	-	-	-		
		1,5	18	18	18	18	20	20	20	23	23	27	27	27	-	-	-	-	-	-	-	-	-	-	-	-	-	-		
50	T1	1	-	-	-	18	20	20	20	23	23	27	27	27	31	31	31	31	31	36	36	36	36	-	-	-	-	-		
		1,5	-	-	-	18	18	20	20	20	23	23	27	27	27	-	-	-	-	-	-	-	-	-	-	-	-	-		
	T2	1	-	-	-	23	25	25	25	25	25	29	29	29	33	33	33	33	33	38	38	38	38	38	38	41	-	-		
		2	23	23	23	23	25	25	25	25	25	29	29	-	-	-	-	-	-	-	-	-	-	-	-	-	-	-		
63	T1	1	-	-	-	-	-	-	-	-	-	29	29	29	33	33	33	33	33	38	38	38	38	38	38	41	-	-		
		2	-	-	-	23	25	25	25	25	25	29	29	-	-	-	-	-	-	-	-	-	-	-	-	-	-	-		
80	T1	1	-	-	-	-	-	-	-	-	-	29	29	29	33	33	33	33	33	38	38	38	38	38	38	41	-	-		
		2	-	-	-	23	25	25	25	25	25	29	29	-	-	-	-	-	-	-	-	-	-	-	-	-	-	-		
	T2	1	-	-	-	-	-	-	-	-	-	-	-	34	38	38	38	38	38	43	43	43	43	43	43	46	46	46		
		2	-	-	-	-	-	-	-	-	-	-	34	34	34	38	38	38	38	38	43	43	43	43	-	-	-	-		
100	T1	1	-	-	-	-	-	-	-	-	-	-	-	-	-	-	-	-	38	38	43	43	43	43	43	43	46	46	46	
		2	-	-	-	-	-	-	-	-	-	-	-	-	-	-	-	-	38	38	43	43	43	43	-	-	-	-	-	

## COUPLINGS

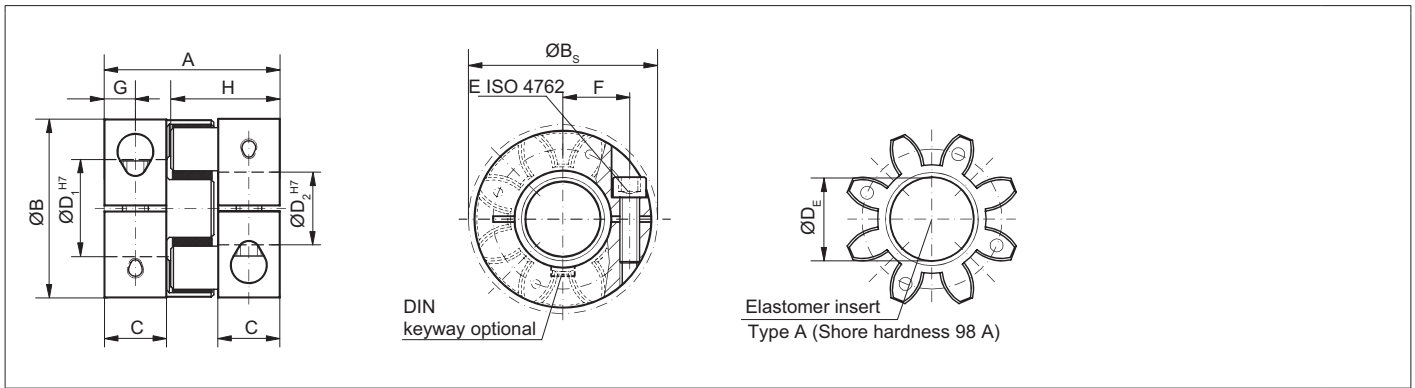

EKL			5	10	20	60	150
Rated torque	[Nm]	$T_{KN}$	9	12,5	17	60	160
Max. torque*	[Nm]	$T_{MAX}$	18	25	34	120	320
Overall length	[mm]	A	26	32	50	58	62
Outside diameter	[mm]	B	25	32	42	56	66,5
Outside diameter with screw head	[mm]	$B_s$	25	32	44,5	57	68
Mounting length	[mm]	C	8	10,3	17	20	21
Inside diameter range H7	[mm]	$D_{1/2}$	4-12,7	4-16	8-25	12-32	19-36
Inside diameter of the elastomer	[mm]	$D_E$	10,2	14,2	19,2	26,2	29,2
Clamping screw (ISO 4752)		E	M3	M4	M5	M6	M8
Tightening torque of the clamping screw	[Nm]	E	2	4	8	15	35
Distance between the centres	[mm]	F	8	10,5	15,5	21	24
Distance	[mm]	G	4	5	8,5	10	11
Hub length	[mm]	H	16,7	20,7	31	36	39
Moment of inertia per hub	[10 <sup>-3</sup> kgm <sup>2</sup> ]	$J_{1/2}$	0,002	0,003	0,01	0,04	0,08
Approximate weight	[kg]		0,02	0,05	0,12	0,3	0,5
Speed standard	[min <sup>-1</sup> ]		15000	13000	12500	11000	10000

\* The maximum transmittable torque of the clamping hub depends on the bore diameter and is limited to the size of the PNCE

### Maximum transmittable and drive torque $M_{p,c}$ [Nm] depends on the bore diameter

EKL	Ø4	Ø5	Ø8	Ø16	Ø19	Ø25	Ø30	Ø32	Ø35
5	1,5	2	8	-	-	-	-	-	-
10	-	4	12	32	-	-	-	-	-
20	-	-	20	35	45	60	-	-	-
60	-	-	-	50	80	100	110	120	-
150	-	-	-	-	120	160	180	200	220

### Maximum transmittable and drive torque $M_{p,c}$ [Nm] limited to the size of the PNCE

EKL	PNCE 32	PNCE 40	PNCE 50	PNCE 63	PNCE 80	PNCE 100
5	2,2	-	-	-	-	-
10	2,2	5,3	13,9	-	-	-
20	-	-	13,9	33,1	-	-
60	-	-	-	35,1	60,7	-
150	-	-	-	-	-	160

## HOW TO ORDER

COUPLING - EKL10 - A - F8 - F14PFN

Coupling

Coupling type/size:  
• 5 • 10 • 20 • 60 • 150

Elastomer insert type:  
• A

Hole diameter

Option:

- PFN: with keyway
- Leave blank: without keyway

## MAGNETIC FIELD SENSORS

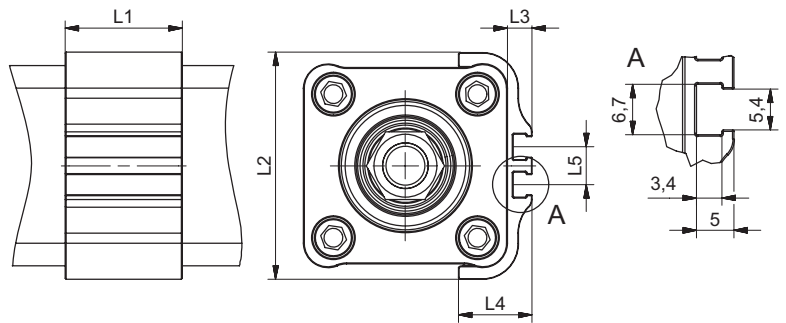
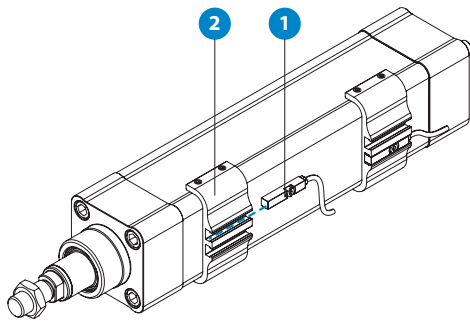

1 - Magnetic field sensor  
2 - Sensor holder

**i** Mounting of the Magnetic field sensor on PNCE requires a HPNCE sensor holder

PNCE	L1	L2	L3	L4	L5
	[mm]				
32	30	53,0	6,5	19,5	10
40	30	60,0	6,5	19,5	10
50	30	71,0	6,5	22,5	10
63	30	81,0	6,5	22,5	10
80	30	98,3	6,0	25,0	10
100	30	115,4	6,0	25,0	10

SMT-65TP-K NO / NC	Code	Type	Compatibility	
	68997	HPNCE sensor holder	PNCE 32	
	68998		PNCE 40	
	68999		PNCE 50	
	69000		PNCE 63	
	79053		PNCE 80	
	79054		PNCE 100	
	74073	SMT-65TP-K NC	PNCE series	
	74074	SMT-65TP-K NO	PNCE series	
	8146	Extension cable length 2m - Straight connector		
	8147	Extension cable length 5m - Straight connector		
	9017	Extension cable length 2m - Angled connector		
	9019	Extension cable length 5m - Angled connector		

TECHNICAL DATA	SMT-65TP-K NC	SMT-65TP-K NO
Sensor Type	GMR sensor	GMR sensor
Switching function	NC	NO
Output	PNP	PNP
Operating voltage	10 ~ 28 V DC	10 ~ 28 V DC
Switching Current	200 mA max.	200 mA max.
Power rating	5,5 W max.	5,5 W max.
Voltage Drop	1,5 V / 200mA max.	1,5 V / 200mA max.
Current Consumption	10mA / 24 V max.	10mA / 24 V max.
Switching Frequency	1000 Hz	1000 Hz
Ambient temperature	-10 ~ +70°C	-10 ~ +70°C
Shock/Vibration	50 G / 9 G	50 G / 9 G
Protection class	IP67	IP67
LED indicator	Yellow	Yellow
Electrical connection	M8, 3-pin	M8, 3-pin
Cable material length	PU - 0,3m	PU - 0,3m
Extension cable	Energy chain compliant	Energy chain compliant

## LOAD TORQUE CALCULATION AND DETERMINATION OF MAXIMUM AXIAL LOAD ON THE PNCE CYLINDER

### Load torque

The load torque is a function of an applied axial load on the PNCE and can be calculated as follows:

$$M_{\text{load}} = \frac{F_{\text{axial}} \times l}{2000 \times \pi \times \eta}$$

When the motor side drive (MSD) is taken into consideration:

$$M_{\text{load}} = \frac{F_{\text{axial}} \times l}{2000 \times \pi \times \eta \times i}$$

$M_{\text{load}}$	Load torque	[Nm]
$F_{\text{axial}}$	Applied axial load on the PNCE	[N]
$l$	Ball screw lead	[mm]
$\eta$	Mechanical efficiency $\approx 0,9$	[-]
$i$	Gear ratio	[-]

**i** It should be noted that the load torque  $M_{\text{load}}$  must never exceed the maximum drive torque  $M_p$

### Maximum axial load on the PNCE

Application conditions example:

- PNCE 40 with ball screw 16x5
- Absolute stroke = 500 mm
- Extended piston rod  $E = 0$  mm
- Travel speed  $v_{\text{max}} = 0,2$  m/s
- Using motor side drive type T1 with a gear ratio  $i = 1,5$
- Mounting: simple – simple mount with SGS and SBG attachment

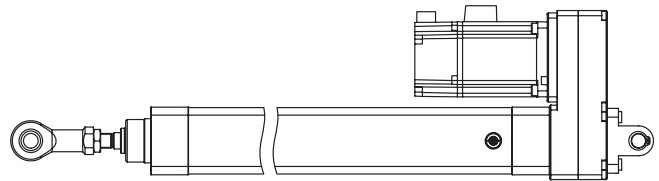

Using the diagram of the maximum axial loading as a function of the absolute stroke, the maximum axial load depending on the given mounting case can be obtained as  $F_{\text{max}} = 700$  N (see page 9).

Using the diagram of the maximum axial loading as a function of the travel speed, the maximum axial load depending on the ball screw lead and absolute stroke can be obtained as  $F_{\text{max}} = 4700$  N (see page 7).

For a selected motor side drive, the maximum drive torque  $M_{p, \text{MSD}} = 2$  Nm can be found (technical data table, see page 30). Using the equation for the load torque calculation when the motor side drive is taken into consideration, the maximum axial load  $F_{\text{max}} = 3392$  N can be calculated.

For selected mounting attachments, the maximum axial load is limited to the maximum axial load of the PNCE, i.e.  $F_{\text{max}} = 6020$  N (see table on page 19/24).

Finally, for this application example, the maximum axial load on the PNCE can be determined, i.e.  $F_{\text{max}} = 700$  N. This is the smallest value of all the values obtained in the previous steps.

# UNIMOTION

## CALCULATE YOUR OWN PROJECT!

The SIZING SELECTION TOOLS are online applications that enables quick and easy selection of a suitable product, with the possibility of achieving the optimal ratio between the given capacity and the price. For more information please contact us or visit our website.

